

MAG-BIT®

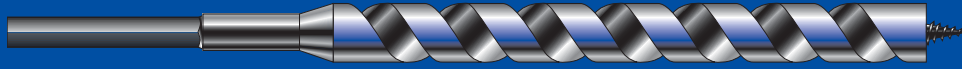

2022 Catalog

PROFESSIONAL GRADE POWER TOOL ACCESSORIES



Tel: 888-MAGBITS (888-624-2487)
Fax: 866-BITGUYS (866-248-4897)

www.magbit.com

MAG-BIT®



FISH-BIT®



CONTACT US:

TEL:
888-MAGBITS
(888-624-2487)

FAX:
866-BITGUYS
(866-248-4897)

www.magbit.com
orderdesk@magbit.com

C O N T E N T S

DRILL BITS

AUGER BITS:

Nailbomber Moly Coated / Ship Head	
Heavy Duty (357DLX, 303DLX).....	4
Ship Head, Regular Duty (715, 735).....	5
Single Spur (701)	6
Single Spur (704, 710)	7
Long Ship (727).....	8
Electrician's Power Bits (770).....	8
Timber/Arborist Bits™ (728, 730, 760).....	9

HIGH SPEED STEEL BITS:

Step Drills (851).....	10
HSS Step Drill Kits (851)	11
Sidewinder Bit (861)	11
HSS Step Drills Information.....	12
Silver & Deming Drills, HSS (901).....	13
Long Boy Drills, HSS (911).....	13
Countershark & Shark Bits (909).....	14
Countershark Kits (909).....	14
Black & Gold Bits and Kits (501)	15
Cobalt Steel Jobbers & Kits (503)	16
Number Drills (105).....	17
Stubby & Aircraft (106, 107)	18

SPECIALTY BITS:

Double End Twist (104) / Self-Feed Bit (785)	19
Moly Coated Self Feed Bits (785).....	20
Heavy Duty Hole Maker Kit (757DLX)	20
Spade Bits (790, 792).....	21
SDS+ Rotary Hammer Drills (101, 102)	22
Concrete Screw Bits (103), Kit.....	23
Carbide Tipped Bell Hanger Drills (781).....	24
Bell Hanger Drills (786)	25
Fish Bit (777) / Guide.....	26
Extensions (782, 625).....	27

HOLE SAWS

Bi-Metal Hole Saws (624).....	28
Hole Saw RPM Chart (624)	29
Bi-Metal Hole Saw kits (624).....	30
Carbide Grit Hole Saws & Kits (625)	31
Canlight Hole Saw (625).....	32
Tungsten Carbide Tipped Hole Cutters (626).....	33
Carbide Tipped Hole Saws (628)	34
Arbors / Pilot Bits (624, 625)	35
Thin Wall Hole Saw (629).....	36

RECIPROCATING SAWS

Bi-Metal Reciprocating Saw Blades (732)	37
Heavy Duty Demolition Blades (732)	38
Heavy Duty Wood Cutting Blade (732)	39
Fast Metal Cutting Blade (732)	39
Scroll Blades (732).....	40
Carbide Grit Reciprocating Blades (732)	40

HAND TOOLS

Tube Cutter / Mini Tube Cutter (801).....	41
Spare Tube Cutter Wheels (801).....	41
Auto Tube Cutter (801)	42
Tape Measure (111).....	42
Cutting Fluid, Mag Lube (901).....	42
Auger Bit File (303DLX-FILE).....	42
Hack Saw Frame (425)	43
Bi-Metal Hand Hack Saw Blade (425).....	43
Mini Hand Hack Saw Frame / Blade (425).....	43
Drywall Saws (600, 700)	44
Heavy Duty PVC Saw (800).....	44
Heavy Duty Ratcheting PVC Pipe Cutter (800)	44
Anchor Kits (480)	45

SCREWDRIVING BITS

Hex Allen (400, 401).....	46
Phillips & Square (415)	46
ACR (408).....	47
Phillips (409)	47
Slotted (412) / Phillips Impact (410).....	48
Posidriv (411).....	48
Spanner (413)	48
Square (416)	49
Impact Resistant (418)	49
Star (417, 418)	50
Dry Wall Driver (414)	51
Double End (422)	51
Tamper Resistant Star (418).....	51
Magnetic Bit Holders (419)	52
Screw Guide Mag. Bit Holders (421)	52
Square Hex Shank Extensions (402, 403)	53
Non-Magnetic Nut Setters (405)	53
Magnetic Nut Setters (407)	54
Lobular Magnetic Nut Setters (407)	54

PLUMBING

Screw Extractors (421).....	55
Stainless Steel Hose Clamps (815)	55

NEW ITEMS

.....	56
-------	----

CROSS REFERENCE CHARTS

Ship Augers Heavy Duty X-Reference Guide (357DLX) ..	57
Ship Augers Heavy Duty X-Reference Guide (303DLX) ..	57-58
Step Drill X-Reference Guide (850, 851)	58
Self Feed X-Reference Guide (785)	58
Bi-Metal Hole Saw X-Reference Guide (624).....	59
Arbor X-Reference Guide (624, 625), Arbors, Pilot.....	60

GENERAL INFORMATION

Auger Bits.....	61-63
Wire Gauge Decimal Table.....	64
Jobber & Aircraft Flute Length	64
Warranty	65

DRILL BITS – Auger Bits



THE NAILBOMBER

357DLX Heavy Duty Ship Augers

8" OAL x 5" Twist Length

SIZE	SHANK SIZE	PART NUMBER	UPC NUMBER 722170-
1/2"	5/16"	357DLX.0816QC	35714
9/16"	7/16"	357DLX.0916QC	35715
5/8"	7/16"	357DLX.1016QC	35716
11/16"	7/16"	357DLX.1116QC	35717
3/4"	7/16"	357DLX.1216QC	35718
13/16"	7/16"	357DLX.1316QC	35719
7/8"	7/16"	357DLX.1416QC	35720
15/16"	7/16"	357DLX.1516QC	35721
1"	7/16"	357DLX.1616QC	35722
1-1/8"	7/16"	357DLX.1816QC	35723
1-1/4"	7/16"	357DLX.2016QC	35724
1-3/8"	7/16"	357DLX.2216QC	35725
1-1/2"	7/16"	357DLX.2416QC	35726

UNIT PACK: 1

303DLX Heavy Duty Ship Augers

18" OAL x 15" Twist Length

SIZE	SHANK SIZE	PART NUMBER	UPC NUMBER 722170-
3/8"	5/16"	303DLX.0616QC	30316
7/16"	5/16"	303DLX.0716QC	30317
1/2"	5/16"	303DLX.0816QC	30331
9/16"	5/16"	303DLX.0916QC	30319
5/8"	7/16"	303DLX.1016QC	30320
11/16"	7/16"	303DLX.1116QC	30321
3/4"	7/16"	303DLX.1216QC	30322
13/16"	7/16"	303DLX.1316QC	30323
7/8"	7/16"	303DLX.1416QC	30324
15/16"	7/16"	303DLX.1516QC	30325
1"	7/16"	303DLX.1616QC	30326
1-1/8"	7/16"	303DLX.1816QC	30327
1-1/4"	7/16"	303DLX.2016QC	30328
1-3/8"	7/16"	303DLX.2216QC	30329
1-1/2"	7/16"	303DLX.2416QC	30330

UNIT PACK: 1



THE NAILBOMBER

- Molybdenum coated for cooler running
- Cuts nails
- Higher Grade Heat-treated high speed steel
- Glides through wood with less binding, bores faster than standard auger bits
- Ejects chips faster
- Stays sharper longer
- No run out, machined on a true center

Molybdenum Coated: Molybdenum cools and lubricates the bit. The bit stays sharper longer because the heat treatment lasts longer. The bit ejects chips and bores faster than ordinary bits and binds less, even in wet or resinous woods.

Deeper Lands: For a stronger less flexible bit.

Countershank: Bits 5/8" and larger in diameter will accept the Mag-Bit counter bore tools, available in 1-1/2", 2-1/4" and 3-1/4" diameters.

Extensions: Quick Change and Universal Shank.



THE NAILBOMBER

- Molybdenum coated for cooler running
- Cuts nails
- Higher Grade Heat-treated high speed steel
- Glides through wood with less binding, bores faster than standard auger bits
- Ejects chips faster
- Stays sharper longer
- No run out, machined on a true center

Molybdenum Coated: Molybdenum cools and lubricates the bit. The bit stays sharper longer because the heat treatment lasts longer. The bit ejects chips and bores faster than ordinary bits and binds less, even in wet or resinous woods.

Deeper Lands: For a stronger less flexible bit.

Countershank: Bits 5/8" and larger in diameter will accept the Mag-Bit counter bore tools, available in 1-1/2", 2-1/4" and 3-1/4" diameters.

Extensions: Quick Change and Universal Shank.

DRILL BITS – Auger Bits

715 Regular Duty Ship Augers

6" OAL x 4" Twist Length

SIZE	SHANK SIZE	PART NUMBER	UPC NUMBER 722170-
1/2"	3/8"	715.0816	71501
9/16"	7/16"	715.0916	71502
5/8"	7/16"	715.1016	71503
11/16"	7/16"	715.1116	71504
3/4"	7/16"	715.1216	71505
13/16"	7/16"	715.1316	71506
7/8"	7/16"	715.1416	71507
15/16"	7/16"	715.1516	71508
1"	7/16"	715.1616	71509
1-1/8"	7/16"	715.1816	71510
1-1/4"	7/16"	715.2016	71511
1-3/8"	7/16"	715.2216	71512
1-1/2"	7/16"	715.2416	71513

UNIT PACK: 1



- Heat-Treated High Speed Steel Auger Bit
- High quality ship auger
- Machined on a true center
- Quick Change shank
- Self-feeding screw point for fast, instant starts and eliminates a center punch hole
- Quick Change and Universal extensions

Versatile high quality fast boring general purpose ship auger bits come with a self-feed screw point for fast, effortless boring.

735 Regular Duty Ship Augers

17" OAL x 12" Twist Length

SIZE	SHANK SIZE	PART NUMBER	UPC NUMBER 722170-
1/4"	1/4"	735.0416	73517
5/16"	5/16"	735.0516	73518
3/8"	3/8"	735.0616	73501
7/16"	3/8"	735.0716	73502
1/2"	3/8"	735.0816	73503
9/16"	7/16"	735.0916	73504
5/8"	7/16"	735.1016	73505
11/16"	7/16"	735.1116	73506
3/4"	7/16"	735.1216	73507
13/16"	7/16"	735.1316	73508
7/8"	7/16"	735.1416	73509
15/16"	7/16"	735.1516	73510
1"	7/16"	735.1616	73511
1-1/16"	7/16"	735.1716	73512
1-1/8"	7/16"	735.1816	73513
1-1/4"	7/16"	735.2016	73514
1-3/8"	7/16"	735.2216	73515
1-1/2"	7/16"	735.2416	73516

UNIT PACK: 1



- Heat-Treated High Speed Steel Auger Bit
- High quality ship auger
- Machined on a true center
- Quick Change shank
- Self-feeding screw point for fast, instant starts and eliminates a center punch hole
- Quick Change and Universal extensions

Versatile high quality fast boring general purpose ship auger bits come with a self-feed screw point for fast, effortless boring.

DRILL BITS – Auger Bits

701 Single Spur Auger Bits

7-7/8" OAL x 5" Twist Length

SIZE	SHANK SIZE	PART NUMBER	UPC NUMBER 722170-
1/4"	1/4"	701.0416	70101
5/16"	5/16"	701.0516	70102
3/8"	3/8"	701.0616	70103
7/16"	3/8"	701.0716	70104
1/2"	3/8"	701.0816	70105
9/16"	3/8"	701.0916	70106
5/8"	3/8"	701.1016	70107
11/16"	3/8"	701.1116	70108
3/4"	3/8"	701.1216	70109
13/16"	3/8"	701.1316	70110
7/8"	3/8"	701.1416	70111
15/16"	3/8"	701.1516	70112
1"	3/8"	701.1616	70113
1-1/16"	7/16"	701.1716	70118
1-1/8"	7/16"	701.1816	70114
1-1/4"	7/16"	701.2016	70115
1-3/8"	7/16"	701.2216	70116
1-1/2"	7/16"	701.2416	70117

UNIT PACK: 1



- Black oxide flutes
- Quick Change shank
- Self-feeding screw point for fast, instant starts and eliminates a center punch hole
- Spur for clean boring
- Packed in a reusable storage tube
- Quick Change and Universal extensions
- Heat-Treated High Speed Steel Auger Bit

Single spur opposite cutting lip for clean entrance and exit holes and a self-feed screw point for fast, effortless boring.

DRILL BITS – Auger Bits

704 Single Spur Auger Bits

13" OAL x 9-1/2" Twist Length

SIZE	SHANK SIZE	PART NUMBER	UPC NUMBER 722170-
5/16"	5/16"	704.0516	70413
3/8"	5/16"	704.0616	70414
7/16"	5/16"	704.0716	70415
1/2"	7/16"	704.0816	70416
9/16"	7/16"	704.0916	70417
5/8"	7/16"	704.1016	70418
11/16"	7/16"	704.1116	70401
3/4"	7/16"	704.1216	70402
13/16"	7/16"	704.1316	70403
7/8"	7/16"	704.1416	70404
15/16"	7/16"	704.1516	70405
1"	7/16"	704.1616	70406
1-1/16"	7/16"	704.1716	70410
1-1/8"	7/16"	704.1816	70407
1-3/16"	7/16"	704.1916	70411
1-1/4"	7/16"	704.2016	70408
1-5/16"	7/16"	704.2116	70412
1-1/2"	7/16"	704.2416	70409

UNIT PACK: 1

710 Single Spur Auger Bits

18" OAL x 12" Twist Length

SIZE	SHANK SIZE	PART NUMBER	UPC NUMBER 722170-
3/8"	5/16"	710.0616	71001
7/16"	5/16"	710.0716	71002
1/2"	5/16"	710.0816	71003
9/16"	7/16"	710.0916	71004
5/8"	7/16"	710.1016	71005
11/16"	7/16"	710.1116	71006
3/4"	7/16"	710.1216	71007
13/16"	7/16"	710.1316	71008
7/8"	7/16"	710.1416	71009
15/16"	7/16"	710.1516	71010
1"	7/16"	710.1616	71011
1-1/16"	7/16"	710.1716	71016
1-1/8"	7/16"	710.1816	71012
1-3/16"	7/16"	710.1916	71017
1-1/4"	7/16"	710.2016	71013
1-5/16"	7/16"	710.2116	71018
1-3/8"	7/16"	710.2216	71014
1-1/2"	7/16"	710.2416	71015

UNIT PACK: 1



SMOOTH HOLES

NO SPLINTERS

- Only available from MAG-BIT
- Black oxide flutes
- Quick Change shank
- Self-feeding screw point for fast, instant starts and eliminates a center punch hole
- Spur for clean boring
- Packed in a reusable storage tube
- Quick Change and Universal extensions
- Heat-Treated High Speed Steel Auger Bit

Use when a 6" bit is too short for the hole and a 18" bit is too long. Single spur opposite cutting lip for clean entrance and exit holes and a self-feed screw point for fast, effortless boring.

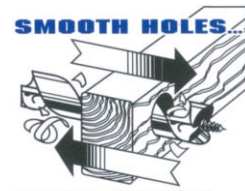

SMOOTH HOLES

NO SPLINTERS

- Black oxide flutes
- Quick Change shank
- Self-feeding screw point
- Spur for clean boring
- Packed in a reusable storage tube
- Quick Change and Universal extensions

Single spur opposite cutting lip for clean entrance and exit holes and a self-feed screw point for fast, effortless boring.

DRILL BITS – Auger Bits

727 Long Auger Bits

23" OAL x 18" Twist Length

SIZE	SHANK SIZE	PART NUMBER	UPC NUMBER 722170-
9/16"	7/16"	727.0916	72701
5/8"	7/16"	727.1016	72702
11/16"	7/16"	727.1116	72703
3/4"	7/16"	727.1216	72704
13/16"	7/16"	727.1316	72705
7/8"	7/16"	727.1416	72706
15/16"	7/16"	727.1516	72707
1"	7/16"	727.1616	72708

UNIT PACK: 1



- Spur for clean boring
- Ship head style
- 7/16" Quick Change shank
- Self-feeding screw point for fast, instant starts and eliminates a center punch hole
- Heat-Treated High Speed Steel Auger Bit

Spur provided along with a self-feed screw point for fast, clean and effortless boring. Extra long reach bit for heavy wood, railroad ties or creosoted poles.

770 Electrician's Power Bits

8-1/2" OAL x 5-1/2" Twist Length

SIZE	SHANK SIZE	PART NUMBER	UPC NUMBER 722170-
5/8"	5/16"	770.1016	77001
11/16"	5/16"	770.1116	77002
3/4"	5/16"	770.1216	77003
13/16"	5/16"	770.1316	77004
7/8"	5/16"	770.1416	77005
1"	5/16"	770.1616	77006
1-1/8"	7/16"	770.1816	77007
1-1/4"	7/16"	770.2016	77008

UNIT PACK: 1



- For electrician's, pipe fitters and plumbers.
- Double flute construction
- Self-feeding screw point with spur for clean boring
- Packed in a reusable storage tube
- Quick Change Shank

Designed to cut through three 2"x4"s between other studs with a right angle drill. Traditional double twist for fast clearance of chips and two cutting edges. Single spur for clean cut holes. A self-feed screw point for fast, effortless boring.

DRILL BITS – Auger Bits

728 Timber/Arborist Bits

40" OAL, 36" Twist Length. 7/16" Hex Q.C. Shank

SIZE	SHANK SIZE	PART NUMBER	UPC NUMBER 722170-
9/16"	7/16"	728.0916	72801
5/8"	7/16"	728.1016	72802
11/16"	7/16"	728.1116	72803
3/4"	7/16"	728.1216	72804
13/16"	7/16"	728.1316	72809
7/8"	7/16"	728.1416	72810
15/16"	7/16"	728.1516	72811
1"	7/16"	728.1616	72812
1-1/16"	7/16"	728.1716	72813
1-1/8"	7/16"	728.1816	72814

UNIT PACK: 1

730 Timber/Arborist Bits

30" OAL, 26" Twist Length. 7/16" Hex Q.C. Shank

SIZE	SHANK SIZE	PART NUMBER	UPC NUMBER 722170-
9/16"	7/16"	730.0916	73001
5/8"	7/16"	730.1016	73002
11/16"	7/16"	730.1116	73003
3/4"	7/16"	730.1216	73004
13/16"	7/16"	730.1316	73005
7/8"	7/16"	730.1416	73006
15/16"	7/16"	730.1516	73007
1"	7/16"	730.1616	73008
1-1/16"	7/16"	730.1716	73009
1-1/8"	7/16"	730.1816	73010
1-1/2"	7/16"	730.2416	73013

UNIT PACK: 1

760 Timber/Arborist Bits

60" OAL, 24" Flute Length, 1/2" Round Shank with 3 Flats

SIZE	SHANK SIZE	PART NUMBER	UPC NUMBER 722170-
11/16"	1/2"	760.1116	76003
13/16"	1/2"	760.1316	76005

UNIT PACK: 1

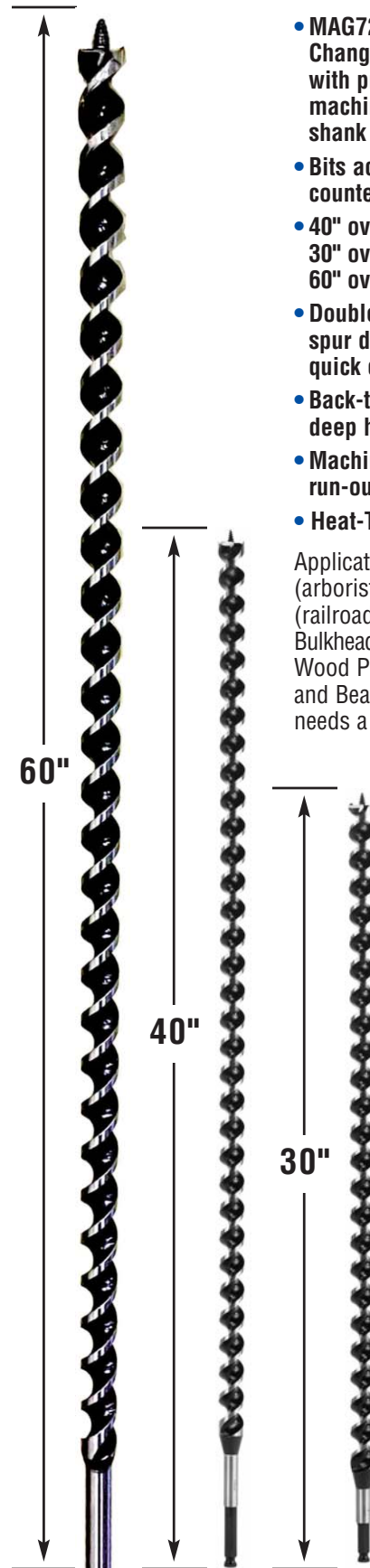

- MAG728 and MAG730 have Quick Change 7/16" hex shank to work with pneumatic and hydraulic drill machines. MAG760 has 1/2" round shank with 3 flats.
- Bits accept Mag-Bit Countershark, counter bore tools.
- 40" overall length with a 36" flute
30" overall length with a 26" flute
60" overall length with a 24" flute
- Double flute and double cutting spur design for clean holes and quick chip removal.
- Back-tapered to prevent binding in deep holes.
- Machined on a true center for less run-out and to prevent wobbling.
- Heat-Treated High Speed Steel bit

Applications: Log Homes, Trees (arborists), Landscape Contractors (railroad ties), Dock Builders, Bulkheads, Remodeling/Renovation, Wood Play-set Manufacturers, Post and Beam Construction, anyone who needs a deep hole or a long reach.

DRILL BITS – High Speed Drill Bits

851 HSS Step Drills

Step drills

NO. OF SMALLEST STEPS	LARGEST DIA.	SHANK DIA.	PART NUMBER	UPC NUMBER 722170-
13	1/8"	1/2"	851.0500A	85131
All Steps: 1/8"-5/32"-3/16"-7/32"-1/4"-9/32"-5/16"-11/32"-3/8"-13/32"-7/16"-15/32"-1/2"				
6	3/16"	1/2"	851.0500B	85132
All Steps: 3/16"-1/4"-5/16"-3/8"-7/16"-1/2"				
9	1/4"	3/4"	851.0750QC	85143
All Steps: 1/4"-5/16"-3/8"-7/16"-1/2"-9/16"-5/8"-11/16"-3/4"				
3	3/8"	3/4"	851.0750B	85137
All Steps: Pilot holes for K.O. punch drive screws 3/8"-7/16"-3/4"				
12	3/16"	7/8"	851.0875QC	85134
All Steps: 3/16"-1/4"-5/16"-3/8"-7/16"-1/2"-9/16"-5/8"-11/16"-3/4"-13/16"-7/8"				
8	5/16"	1"	851.1000	85141
All Steps: 9/16"-5/8"-11/16"-3/4"-13/16"-7/8"-15/16"-1"				
12	7/16"	1-1/8"	851.1125	85135
All Steps: 7/16"-1/2"-9/16"-5/8"-11/16"-3/4"-13/16"-7/8"-15/16"-1"-1.1/16"-1.1/8"				
2	7/8"	1-1/8"	851.1125B	85138
All Steps: 7/8"-1.1/8"				
11	3/4"	1-3/8"	851.1375	85136
All Steps: 3/4"-13/16"-7/8"-15/16"-1"-1.1/16"-1.1/8"-1.13/16"-1.1/4"-1.5/16"-1.3/8"				
5	7/8"	1-3/8"	851.1375B	85139
All Steps: 7/8" for 1/2" conduit - 1.1/8" for 3/4" conduit - 1.7/32" for oil tight switch - 1.1/4"-1.3/8" for 1" conduit				
11	1/4"	1-1/2"	851.1500	85140
All Steps: 1/4"-3/8"-1/2"-5/8"-3/4"-7/8"-1.1/8"-1.1/4"-1.3/8"-1.1/2"				

UNIT PACK: 1



- Two flutes for cleaner cut
- 135° split point prevents walking/wobbling
- Self centering split point
- Perfect for drilling multiple holes with one single drill bit

High speed steel drills for multiple-size, perfectly round, burr-free holes in thin materials. No pilot hole required. For use in sheet steel, non-ferrous metal, pvc, plastic laminates such as Formica and even plywood.

⚠ When drilling metals, use a cutting compound such as MAG-LUBE *concentrated cutting fluid*.

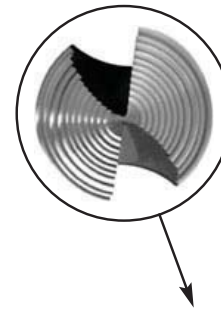

Two flutes for cleaner cut. Split point prevents walking.

Part No. 851-0500A, 851-0500B, 851.0750QC AND 851.0875QC have Q.C. Hex Shank. All other Shanks w/3 Flats

851.1500-08 ★ & 851.0500A



Together, these two bits cover all usual holes from 1/8" through 1-1/2". ★ 3 flute design.

851.0750B



Drills pilot holes for the 3 most popular sizes of knock out punch drive screws: 3/8", 7/16" and 3/4".

851.0875QC



12 step bit drills holes from 3/16" to 7/8".

851.1375B



7/8" hole for 1/2" conduit, 1-1/8" hole for 3/4" conduit, 1-3/8" hole for 1" conduit, 1-7/32" hole for oil-tight switches.

DRILL BITS – High Speed Drill Bits



Step Drill Kits

PART NUMBER	UPC NUMBER
851 Kit 1	722170-85116
Electrician's Step Drill Kit 1 includes 851.1375B / 851.0050A / 851.1000	

861 Sidewinder Bit



Step Drills

NO. OF STEPS	SMALLEST DIA.	LARGEST DIA.	SHANK SIZE	PART NO.	UPC NUMBER
13	1/8"	1/2"	1/4" Quick Change	861-0500A	86131
Range of Steps: 1/8", 5/32", 3/16", 7/32", 1/4", 9/32", 5/16", 11/32", 3/8", 13/32", 7/16", 15/32", 1/2"					
6	3/16"	1/2"	1/4" Quick Change	861-0500B	86132
Range of Steps: 3/16", 1/4", 5/16", 3/8", 7/16", 1/2"					
3	3/8"	3/4"	1/4" Quick Change	861-0750B	86137
Range of Steps: 3/8", 7/16", 3/4"					
9	1/4"	3/4"	1/4" Quick Change	861-0750QC	86143
Range of Steps: 1/4", 5/16", 3/8", 7/16", 1/2", 9/16", 5/8", 11/16", 3/4"					
12	3/16"	7/8"	1/4" Quick Change	861-0875QC	86134
Range of Steps: 3/16", 1/4", 5/16", 3/8", 7/16", 1/2", 9/16", 5/8", 11/16", 3/4", 13/16", 7/8"					
8	9/16"	1"	3/8" HEX	861-1000	86141
Range of Steps: 9/16", 5/8", 11/16", 3/4", 13/16", 7/8", 15/16", 1"					
2	7/8"	1-1/8"	3/8" HEX	861-1125B	86138
Range of Steps: 7/8", 1-1/8"					
12	7/16"	1-1/8"	3/8" HEX	861-1125	86135
Range of Steps: 7/16", 1/2", 9/16", 5/8", 11/16", 3/4", 13/16", 7/8", 15/16", 1", 1-1/16", 1-1/8"					
5	7/8"	1-3/8"	3/8" HEX	861-1375B	86139
Range of Steps: 7/8", 1-1/8", 1-7/32", 1-1/4", 1-3/8"					
11	3/4"	1-3/8"	3/8" HEX	861-1375	86136
Range of Steps: 3/4", 13/16", 7/8", 15/16", 1", 1-1/16", 1-1/8", 1-13/16", 1-1/4", 1-5/16", 1-3/8"					
11	1/4"	1-1/2"	3/8" HEX	861-1500	86140
Range of Steps: 1/4", 3/8", 1/2", 5/8", 3/4", 7/8", 1", 1-1/8", 1-1/4", 1-3/8", 1-1/2"					

- Perfect for drilling and enlarging multiple holes with one single drill bit to save time and money
- Heavy duty, heat-treated High Speed Steel material for a stronger and longer lasting step drill
- Chamfered steps allows the user to gradually drill to the desired size for clean, burr-free holes
- 135° Split Point tip eliminates "wobbling/walking" by self starting and self centering the drill bit to not require center punch holes
- SPIRAL flutes cut and drill faster than traditional step drills. Chip flow is optimized and heat is removed faster for a "cooler" bit
- Multipurpose drill bit for cutting through metal, brass, and plastic

DRILL BITS – High Speed Steel Bits

MAG-BIT offers a wider selection of step drills than any other manufacturer.

Step Drills – Features, benefits and uses:

Applications:	Electrical, Plumbing, Construction, HVAC, Control Panels, Sheet Metal Work, Auto Body Repair, Shopfitting Installations.
Materials:	Burr free holes in Sheet Metal, Stainless Steel, Non-Ferrous Metals, Cast Iron, Plastics, Formica, Plywood.
Benefits:	Perfectly round holes, Self-centering. No pilot hole required (except Reamers). Special point prevents "walking". Two flutes and two cutting blades for chatter free cutting. Automatic de-burring. Stronger, more rigid than standard drills. Multiple holes from one bit. Three lobed shank will not slip in any chuck. Steam oxide finish for long life.
Drilling Depth:	The maximum material thickness is determined by the length of the step. If the workpiece can be reversed, multiply the depth by 2.

Step Drills

Part No.	No. Holes	Min./Max Diameter	Shank	Application
851.0500A	13	1/8" - 1/2"	1/4"	> Together these two bits cover all usual holes from 1/8" through 1-1/2"
851.1500	11	1/4" - 1-1/2"	1/2"	
851.1000	5	9/16" - 1"	3/8"	All drilling applications
851.0750QC	9	1/4" - 3/4"	1/4"	All drilling applications
851.1125	12	7/16" - 1-1/8"	3/8"	All drilling applications
851.1375	11	3/4" - 1-3/8"	1/2"	All drilling applications
851.0875QC	12	3/16" - 7/8"	1/4"	All drilling applications
851.0500B	6	3/16" - 1/2"	1/4"	All drilling applications

Specialty Drills: All specialty drills have extra step length at specified diameters for easy identification.

Part No.	No. Holes	Specified Diameters	Shank	Application
851.1125B	2	7/8" - 1-1/8"	3/8"	7/8" hole for 1/2" conduit, 1-1/8" for 3/4" conduit.
851.1375B	5	7/8" - 1-1/8" - 1-7/32" 1-1/4" - 1-3/8"	3/8"	7/8" hole for 1/2" conduit, 1-1/8" hole for 3/4" conduit, 1-3/8" hole for 1" conduit, 1-7/32" hole for oil-tight switches
851.0750B	3	3/8" - 7/16" - 3/4"	3/8"	3 standard holes to accommodate drive screws for Knock-Out punches



When drilling metals use a cutting compound such as MAG-LUBE *concentrated cutting fluid*.

DRILL BITS – High Speed Steel Bits

901 Silver & Deming Drills

5-5/8" OAL x 4" Twist Length

SIZE	SHANK SIZE	PART NUMBER	UPC NUMBER 722170-
9/16"	1/2"	901.0916	90102
5/8"	1/2"	901.1016	90104
11/16"	1/2"	901.1116	90106
3/4"	1/2"	901.1216	90108
13/16"	1/2"	901.1316	90110
7/8"	1/2"	901.1416	90112
15/16"	1/2"	901.1516	90114
1"	1/2"	901.1616	90116
1-1/16"	1/2"	901.1716	90117
1-1/8"	1/2"	901.1816	90118
1-3/16"	1/2"	901.1916	90119
1-1/4"	1/2"	901.2016	90120

UNIT PACK: 1



- 118° split point prevents walking/wobbling and eliminates the need for a pilot center hole
- 1/2" Shank with 3 flats
- M2 High Speed Steel
- Specially designed flutes for better chip ejection
- Packed in a reusable storage tube

Useful in applications where the Mag-Bit Long Boy is too long.

911 Long Boy Drill Bits

12" OAL x 9" Twist Length

SIZE	SHANK SIZE	PART NUMBER	UPC NUMBER 722170-
7/16"	1/2" w/ 3 flats	911.0716	91100
1/2"	1/2" w/ 3 flats	911.0816	91101
9/16"	1/2" w/ 3 flats	911.0916	91102
5/8"	1/2" w/ 3 flats	911.1016	91103
11/16"	1/2" w/ 3 flats	911.1116	91104
3/4"	1/2" w/ 3 flats	911.1216	91105
13/16"	1/2" w/ 3 flats	911.1316	91106
7/8"	1/2" w/ 3 flats	911.1416	91107
15/16"	1/2" w/ 3 flats	911.1516	91108
1"	1/2" w/ 3 flats	911.1616	91109
1-1/16"	1/2" w/ 3 flats	911.1716	91110
1-1/8"	1/2" w/ 3 flats	911.1816	91111
1-1/4"	1/2" w/ 3 flats	911.2016	91112

UNIT PACK: 1

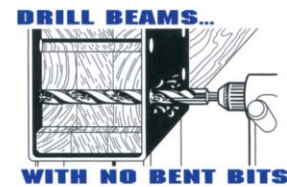

- High speed steel
- 1/2" shank with 3 flats
- 118° Split Point, Prevents Walking
- Packed in a reusable storage tube
- Bulk program available

Designed to give the roofing and framing contractor more holes per bit using pre-drilled joist hangers, anchors, caps and connectors. Drill beams-don't bend bits.

DRILL BITS – High Speed Steel Bits



SHARK-BIT®

909 Shark-Bits

9" OAL x 6" Twist Length

SIZE	PART NUMBER	UPC NUMBER 722170-
9/16"	909.0916	90902
11/16"	909.1116	90903
13/16"	909.1316	90904

UNIT PACK: 1



COUNTER SHARK®

909 Countershark

SIZE	PART NUMBER	UPC NUMBER 722170-
1-1/2"	909.2416	90910
2-1/4"	909.3616	90911
3-1/4"	909.5216	90912

UNIT PACK: 1

909 Kits

MAG 909 KIT1 2 piece kit

KIT NUMBER	KIT PARTS	PART SIZE	UPC NUMBER 722170-
909.Kit1	909.1116	11/16"	90921
	909.3616	2-1/4"	

Packaged in a clear plastic clamshell

MAG 909 KIT2 4 piece kit

KIT NUMBER	KIT PARTS	PART SIZE	UPC NUMBER 722170-
909.Kit2	909.0916	9/16"	90922
	909.1116	11/16"	
	909.1316	13/16"	
	909.3616	2-1/4"	

Packaged in a clear plastic clamshell

MAG 909 KIT3 3 piece kit

KIT NUMBER	KIT PARTS	PART SIZE	UPC NUMBER 722170-
909.Kit3	909.2416	1-1/2"	90923
	909.3616	2-1/4"	
	909.5216	3-1/4"	

Packaged in a clear plastic clamshell



- Shark-Bits available in 9/16", 11/16" and 13/16" diameters.
- Makes more holes in Glue Lam Joists and other engineered wood products than auger bits.
- High Speed Steel will drill through steel (use Mag-Lube cutting fluid).
- Packed in a reusable storage tube

Designed to work with MAG-BIT's Countershark counter-bore tool, these 9" bits have a flat on one side of the shaft to accommodate the set screw on the Countershark.



- Counter-bore for use in all types of wood.
- Use with Mag-Bit Shark bit or MAG303DLX, 357DLX, 735, 715 and 710 auger bits 5/8" diameter or larger to drill clearance holes for bolts and countersink the head and washer in one action.
- Securely attaches to bit with a heavy duty set screw.
- Six super sharp teeth on the outer diameter cut a clean hole and leave a smooth finish at the bottom of the workpiece.
- Packaged in a clear plastic clamshell



DRILL BITS – High Speed Steel Bits

501 Black & Gold Jobber Bits



- Heat-Treated High Speed Steel
- Precision ground from solid
- Straight, Round Shank on diameters 11/64" and under
- 3 Flats Shank on diameters 3/16" and up
- 135 Degree Split Point – Prevent wobbling

SIZE	OAL	PART NUMBER	UPC NUMBER 722170-
1/16"	1-7/8"	501.0464	50101
5/64"	2"	501.0564	50102
3/32"	2-1/4"	501.0664	50103
7/64"	2-5/8"	501.0764	50104
1/8"	2-3/4"	501.0864	50105
9/64"	2-7/8"	501.0964	50106
5/32"	3-1/8"	501.1064	50107
11/64"	3-1/4"	501.1164	50108
3/16"	3-1/2"	501.1264	50109
13/64"	3-5/8"	501.1364	50110
7/32"	3-3/4"	501.1464	50111
15/64"	3-7/8"	501.1564	50112
1/4"	4"	501.1664	50113
17/64"	4-1/8"	501.1764	50114
9/32"	4-1/4"	501.1864	50115
19/64"	4-3/8"	501.1964	50116
5/16"	4-1/2"	501.2064	50117
21/64"	4-5/8"	501.2164	50118
11/32"	4-3/4"	501.2264	50119
23/64"	4-7/8"	501.2364	50120
3/8"	5"	501.2464	50121
25/64"	5-1/8"	501.2564	50122
13/32"	5-1/4"	501.2664	50123
27/64"	5-3/8"	501.2764	50124
7/16"	5-1/2"	501.2864	50125
29/64"	5-5/8"	501.2964	50126
15/32"	5-3/4"	501.3064	50127
31/64"	5-7/8"	501.3164	50128
1/2"	6"	501.3264	50129

19/64" and smaller = 12 PER PACK

5/16" and larger = 6 PER PACK

501 Black & Gold Kits



Twist Drill Sets (Metal Index Box)

NO. OF PIECES	INCLUDES	PART NUMBER	UPC NUMBER 722170-
13	1/16"...1/4" by 64ths	501.1300S	50130
21	1/16"...1/4" by 64ths & 9/32"...1/2" by 32nds	501.2100S	50131
29	1/16"...1/2" by 64ths	501.2900S	50132



Bit Buddy

NO. OF PIECES	INCLUDES	PART NUMBER	UPC NUMBER 722170-
29	1/16"...1/2"	501.2900B	50133

DRILL BITS – High Speed Steel Bits

503 Cobalt Steel Jobber Bits

Cobalt steel makes the drill more durable than a Black & Gold. Due to the hardness being uniform, Cobalt drills can be repeatedly sharpened without damaging the cutting edge allowing it to cut more than HSS drills. Great for linear cutting of hard materials such as stainless steel.



- Cobalt Steel
- Precision ground from solid
- Straight, Round Shank on diameters 11/64" and under
- 3 Flats Shank on diameters 3/16" and up
- 135 Degree Split Point – Prevent wobbling

SIZE	OAL	PART NUMBER	UPC NUMBER 722170-
1/16"	1-7/8"	503.0464	50301
5/64"	2"	503.0564	50302
3/32"	2-1/4"	503.0664	50303
7/64"	2-5/8"	503.0764	50304
1/8"	2-3/4"	503.0864	50305
9/64"	2-7/8"	503.0964	50306
5/32"	3-1/8"	503.1064	50307
11/64"	3-1/4"	503.1164	50308
3/16"	3-1/2"	503.1264	50309
13/64"	3-5/8"	503.1364	50310
7/32"	3-3/4"	503.1464	50311
15/64"	3-7/8"	503.1564	50312
1/4"	4"	503.1664	50313
17/64"	4-1/8"	503.1764	50314
9/32"	4-1/4"	503.1864	50315
19/64"	4-3/8"	503.1964	50316
5/16"	4-1/2"	503.2064	50317
21/64"	4-5/8"	503.2164	50318
11/32"	4-3/4"	503.2264	50319
23/64"	4-7/8"	503.2364	50320
3/8"	5"	503.2464	50321
25/64"	5-1/8"	503.2564	50322
13/32"	5-1/4"	503.2664	50323
27/64"	5-3/8"	503.2764	50324
7/16"	5-1/2"	503.2864	50325
29/64"	5-5/8"	503.2964	50326
15/32"	5-3/4"	503.3064	50327
31/64"	5-7/8"	503.3164	50328
1/2"	6"	503.3264	50329

19/64" and smaller = 12 PER PACK
5/16" and larger = 6 PER PACK

503 Cobalt Steel Jobber Kits



Twist Drill Sets (Metal Index Box)

NO. OF PIECES	INCLUDES	PART NUMBER	UPC NUMBER 722170-
13	1/16"...1/4" by 64ths	503.1300S	50330
21	1/16"...1/4" by 64ths & 9/32"...1/2" by 32nds	503.2100S	50331
29	1/16"...1/2" by 64ths	503.2900S	50332



Bit Buddy

NO. OF PIECES	INCLUDES	PART NUMBER	UPC NUMBER 722170-
29	1/16"...1/2"	503.2900B	50333

DRILL BITS – High Speed Steel Bits

105 Number Drills

- Heat-Treated High Speed Steel
- Precision ground from solid
- Black Oxide Finish adds wear and corrosion resistance
- 135° Split Point prevents wobbling to eliminate the need for a center pilot hole
- Perfect for drilling in wood and metal



WIRE GAUGE	OAL	PART NUMBER	UPC NUMBER 722170-
#1	3-7/8"	105.J101	10501
#2	3-7/8"	105.J102	10502
#3	3-3/4"	105.J103	10503
#4	3-3/4"	105.J104	10504
#5	3-3/4"	105.J105	10505
#6	3-3/4"	105.J106	10506
#7	3-5/8"	105.J107	10507
#8	3-5/8"	105.J108	10508
#9	3-5/8"	105.J109	10509
#10	3-5/8"	105.J110	10510
#11	3-1/2"	105.J111	10511
#12	3-1/2"	105.J112	10512
#13	3-1/2"	105.J113	10513
#14	3-3/8"	105.J114	10514
#15	3-3/8"	105.J115	10515
#16	3-3/8"	105.J116	10516
#17	3-3/8"	105.J117	10517
#18	3-1/4"	105.J118	10518
#19	3-1/4"	105.J119	10519
#20	3-1/4"	105.J120	10520
#21	3-1/4"	105.J121	10521
#22	3-1/8"	105.J122	10522
#23	3-1/8"	105.J123	10523
#24	3-1/8"	105.J124	10524
#25	3"	105.J125	10525
#26	3"	105.J126	10526
#27	3"	105.J127	10527
#28	2-7/8"	105.J128	10528
#29	2-7/8"	105.J129	10529
#30	2-3/4"	105.J130	10530

UNIT PACK: 12

WIRE GAUGE	OAL	PART NUMBER	UPC NUMBER 722170-
#31	2-3/4"	105.J131	10531
#32	2-3/4"	105.J132	10532
#33	2-5/8"	105.J133	10533
#34	2-5/8"	105.J134	10534
#35	2-5/8"	105.J135	10535
#36	2-1/2"	105.J136	10536
#37	2-1/2"	105.J137	10537
#38	2-1/2"	105.J138	10538
#39	2-3/8"	105.J139	10539
#40	2-3/8"	105.J140	10540
#41	2-3/8"	105.J141	10541
#42	2-1/4"	105.J142	10542
#43	2-1/4"	105.J143	10543
#44	2-1/8"	105.J144	10544
#45	2-1/8"	105.J145	10545
#46	2-1/8"	105.J146	10546
#47	2"	105.J147	10547
#48	2"	105.J148	10548
#49	2"	105.J149	10549
#50	2"	105.J150	10550
#51	2"	105.J151	10551
#52	1-7/8"	105.J152	10552
#53	1-7/8"	105.J153	10553
#54	1-7/8"	105.J154	10554
#55	1-7/8"	105.J155	10555
#56	1-3/4"	105.J156	10556
#57	1-3/4"	105.J157	10557
#58	1-5/8"	105.J158	10558
#59	1-5/8"	105.J159	10559
#60	1-5/8"	105.J160	10560

UNIT PACK: 12

See page 63 for Decimal Equivalents table

DRILL BITS – High Speed Steel Bits

106 Aircraft



Straight Shank – Extended Length

- Heat-Treated High Speed Steel
- Precision ground from solid
- Black Oxide Finish adds wear and corrosion resistance
- 135° Split Point prevents wobbling to eliminate the need for a center pilot hole
- Perfect for drilling in wood and metal

SIZE	OAL	PART NUMBER	UPC NUMBER 722170-
1/8"	6"	106.06.0432	10611
5/32"	6"	106.06.0532	10612
3/16"	6"	106.06.0632	10613
7/32"	6"	106.06.0732	10614
1/4"	6"	106.06.0832	10615
9/32"	6"	106.06.0932	10616
5/16"	6"	106.06.1032	10617
3/8"	6"	106.06.1232	10618
7/16"	6"	106.06.1432	10619
1/2"	6"	106.06.1632	10601
1/8"	12"	106.12.0432	10602
5/32"	12"	106.12.0532	10603
3/16"	12"	106.12.0632	10604
7/32"	12"	106.12.0732	10605
1/4"	12"	106.12.0832	10606
9/32"	12"	106.12.0932	10607
5/16"	12"	106.12.1032	10608
3/8"	12"	106.12.1232	10609
1/2"	12"	106.12.1632	10610

UNIT PACK: 1

107 Stubby



Straight Shank – Screw Machine Length

- Heat-Treated High Speed Steel
- Precision ground from solid
- Black Oxide Finish adds wear and corrosion resistance
- 135° Split Point prevents wobbling to eliminate the need for a center pilot hole
- Perfect for drilling in wood and metal

SIZE	OAL	PART NUMBER	UPC NUMBER 722170-
1/16"	1-5/8"	107.0464	10701
1/8"	1-7/8"	107.0864	10702
9/64"	1-15/16"	107.0964	10703
5/32"	2-1/16"	107.1064	10704
11/64"	2-1/8"	107.1164	10705
3/16"	2-3/16"	107.1264	10706
7/32"	2-3/8"	107.1464	10707
1/4"	2-1/2"	107.1664	10708
9/32"	2-11/16"	107.1864	10709
5/16"	2-13/16"	107.2064	10710
3/8"	3-1/8"	107.2464	10711
7/16"	3-7/16"	107.2864	10712
1/2"	3-3/4"	107.3264	10713

9/32" and smaller = 12 PER PACK

5/16" and larger = 6 PER PACK

DRILL BITS – Specialty Bits

104 Double End Twist



Double Cutting Tips

- Heat-Treated High Speed Steel
- Precision ground from solid
- Black Oxide Finish adds wear and corrosion resistance
- 135° Split Point prevents wobbling to eliminate the need for a center pilot hole
- Perfect for drilling in wood and metal

Split Point and black oxide coating resists wear and eliminates wobbling. Ideal for use in stationary drills and working with wood, metal, and plastic.

LENGTH	OAL	PART NUMBER	UPC NUMBER 722170-
1/4"	2-1/2"	104.0416	10401
1/8"	2"	104.0216	10402
3/16"	2-3/16"	104.0316	10403
#30	2"	104.3135	10404

UNIT PACK: 1

785P Non Moly-Coated Self Feed Bit



- Heat-Treated High Speed Alloy Steel
- Self Centering Screw Point
- 1/2" Hex Shank
- Interchangeable Screw Points
- Includes 1 hex key and 1 screw point

Multiple outlining spurs quickly bore precise holes without chipping or splintering. Ideal for plumbers, electricians, carpenters, or anyone who needs to drill large holes in wood.

DIA.	OAL	PART NUMBER	UPC NUMBER 722170-
1"	6"	785.1616P	78530
1-1/8"	6"	785.1816P	78531
1-1/4"	6"	785.2016P	78532
1-3/8"	6"	785.2216P	78533
1-1/2"	6"	785.2416P	78534
1-3/4"	6"	785.2816P	78535
2"	6"	785.3216P	78536
2-1/8"	6"	785.3416P	78537
2-1/4"	6"	785.3616P	78538
2-9/16"	6"	785.4116P	78539
3"	6"	785.4816P	78540
3-5/8"	6"	785.5816P	78541
4-5/8"	6"	785.7416P	78542

UNIT PACK: 1 PER BOX



Replacement Screw Points

COMPATIBLE SIZES	PART NUMBER	UPC NUMBER 722170-
1-3/8"...2-9/16"	785.RSC.100	78547
3"...4-5/8"	785.RSC.200	78548

UNIT PACK: 1

DRILL BITS – Specialty Bits

785 Moly-Coated Self Feed Bits

6" OAL

SIZE	SHANK SIZE	PART NUMBER	UPC NUMBER 722170-
1"	7/16" QC	785.1616	78517
1-1/8"	7/16" QC	785.1816	78518
1-1/4"	7/16" QC	785.2016	78519
1-3/8"	7/16" QC	785.2216	78520
1-1/2"	7/16" QC	785.2416	78521
1-3/4"	7/16" QC	785.2816	78522
2"	7/16" QC	785.3216	78523
2-1/8"	7/16" QC	785.3416	78524
2-1/4"	7/16" QC	785.3616	78525
2-9/16"	7/16" QC	785.4116	78526
3"	7/16" QC	785.4816	78527
3-5/8"	7/16" QC	785.5816	78528
4-5/8"	7/16" QC	785.7416	78529

UNIT PACK: 1



- Molybdenum coated for cooler running which causes bit to last longer
- Glides through woods with less binding
- Quick Change 7/16" hex shank.
- Packaged in box with hang tag.
- Wide throat ejects chips more effectively.
- Lasts longer than the Multi-Spur Self-Feed Bits.
- Self Centering Screw Point prevents wobbling

Designed for high speed cutting of large holes for pipe or conduit placement. The wide throat allows fast chip removal with no clogging. The Quick Change shank has two recesses to allow for a tight fit when using Mag-Bit extensions.

DIAMETER	ENTRANCE FOR PIPE & CONDUIT	ENTRANCE FOR TUBING
1"	1/2"	7/8"
1-1/8"	1/2"	1"
1-1/4"	3/4"	1-1/8"
1-3/8"	1"	1-1/4"
1-1/2"	1-3/8"	
1-3/4"	1-1/4"	1-1/2"
2"	1-1/2"	1-7/8"
2-1/8"		2"
2-1/4"		2-1/8"
2-9/16"	2"	2-1/2"
3"	2-1/2"	2-7/8"
3-5/8"	3"	3-1/2"
4-5/8"	4"	4-1/2"

Pilot Drill Replacement



SIZE	FITS	TYPE OF POINT	PART NUMBER	UPC NO. 722170-
3/16" Rnd	1" to 1-1/2"	Single end Screw pt.	785A.0316	78508
1/4" Rnd	1-3/4" to 3"	Single end Screw pt.	785B.0416	78509
3/8" Rnd	3-5/8" & 4-5/8"	Single end Screw pt.	785C.0616	78510

757DLX Heavy Duty Hole Maker Kit

Heavy Duty Hole Maker Kit
MAG 757DLX-9000

BITS INCLUDED	PART NUMBER	SIZE	UPC NUMBER 722170
Auger Bits	357DLX.1416QC	7/8"	75701
	357DLX.1816QC	1-1/8"	
	357DLX.2016QC	1-1/4"	
	357DLX.2416QC	1-1/2"	
Self Feed Bits	785.2816	1-3/4"	
	785.3416	2-1/8"	
	785.4116	2-9/16"	
Extension	782.95.0716QC	7/16" x 9-1/2"	
Step Drill	851.0875QC	7/8"	



Kit Includes:

- 4 Nailbomber Auger Bits
- 3 Moly Coated Self Feed Bits
- 1 Step Drill
- 1 Extension
- Hex Keys
- Replacement Screw Points

DRILL BITS – Specialty Bits

790 Spade Bits

16" OAL

SIZE	SHANK SIZE	PART NUMBER	UPC NUMBER 722170-
1/4"	1/4"	790.0416	79008
5/16"	1/4"	790.0516	79019
3/8"	1/4"	790.0616	79009
7/16"	1/4"	790.0716	79020
1/2"	1/4"	790.0816	79010
9/16"	1/4"	790.0916	79021
5/8"	1/4"	790.1016	79011
11/16"	1/4"	790.1116	79022
3/4"	1/4"	790.1216	79012
13/16"	1/4"	790.1316	79023
7/8"	1/4"	790.1416	79013
15/16"	1/4"	790.1516	79024
1"	1/4"	790.1616	79014
1-1/8"	1/4"	790.1816	79015
1-1/4"	1/4"	790.2016	79016
1-3/8"	1/4"	790.2216	79017
1-1/2"	1/4"	790.2416	79018

UNIT PACK: 1

- Most economical way to bore holes in wood
- Quick Change Shank
- Fish eye hole
- Heat-Treated forged high speed steel
- Double cutting spurs makes these bits very aggressive and outlines the hole while cutting



792 Spade Bits

6" OAL

SIZE	SHANK SIZE	PART NUMBER	UPC NUMBER 722170-
1/4"	1/4"	792.0416	79222
5/16"	1/4"	792.0516	79223
3/8"	1/4"	792.0616	79224
7/16"	1/4"	792.0716	79225
1/2"	1/4"	792.0816	79226
9/16"	1/4"	792.0916	79227
5/8"	1/4"	792.1016	79228
11/16"	1/4"	792.1116	79229
3/4"	1/4"	792.1216	79230
13/16"	1/4"	792.1316	79231
7/8"	1/4"	792.1416	79232
15/16"	1/4"	792.1516	79233
1"	1/4"	792.1616	79234
1-1/8"	1/4"	792.1816	79235
1-1/4"	1/4"	792.2016	79236
1-3/8"	1/4"	792.2216	79237
1-1/2"	1/4"	792.2416	79238

UNIT PACK: 1



6-piece set includes: 3/8", 1/2", 5/8", 3/4", 7/8", and 1".

13-piece set includes: one each from 1/4" to 1".

MAG 792 Spade Bit Kits

*Reusable vinyl pouch

6 pc. Set / Pouched*	792.6000P	79241
13 pc. Set / Pouched*	792.1300P	79242



DRILL BITS – Specialty Bits

102 SDS+ Hammer Drills

SDS+ Shank

- Industrial Quality Rotary Hammer Drill Bits
- Carbide Tipped for fast drilling in brick, concrete, tile, and masonry
- Fully Heat-Treated Alloy Steel
- High level of shock resistance allows for heavy duty use



SIZE	OAL	PART NUMBER	UPC NUMBER 722170-
3/16"	4"	102.04.0316	10201
1/4"	4"	102.04.0416	10206
3/16"	6"	102.06.0316	10202
1/4"	6"	102.06.0416	10207
5/16"	6"	102.06.0516	10210
3/8"	6"	102.06.0616	10212
7/16"	6"	102.06.0716	10216
1/2"	6"	102.06.0816	10219
9/16"	6"	102.06.0916	10223
5/8"	6"	102.06.1016	10226
3/16"	9"	102.09.0316	10203
1/4"	9"	102.09.0416	10208
5/16"	9"	102.09.0516	10211
3/8"	9"	102.09.0616	10213
1/2"	9"	102.09.0816	10220
5/8"	9"	102.09.1016	10227
3/4"	9"	102.09.1216	10230
7/8"	9"	102.09.1416	10233
1"	9"	102.09.1616	10236
3/16"	12"	102.12.0316	10204
1/4"	12"	102.12.0416	10209

UNIT PACK: 1

SIZE	OAL	PART NUMBER	UPC NUMBER 722170-
5/16"	12"	102.12.0516	10239
3/8"	12"	102.12.0616	10214
7/16"	12"	102.12.0716	10217
1/2"	12"	102.12.0816	10221
9/16"	12"	102.12.0916	10224
5/8"	12"	102.12.1016	10228
3/4"	12"	102.12.1216	10231
7/8"	12"	102.12.1416	10234
1"	12"	102.12.1616	10237
3/8"	18"	102.18.0616	10215
7/16"	18"	102.18.0716	10218
1/2"	18"	102.18.0816	10222
9/16"	18"	102.18.0916	10225
5/8"	18"	102.18.1016	10229
3/4"	18"	102.18.1216	10232
7/8"	18"	102.18.1416	10235
1"	18"	102.18.1616	10238
3/8"	24"	102.24.0616	10243
1/2"	24"	102.24.0816	10241
5/8"	24"	102.24.1016	10244
3/4"	24"	102.24.1216	10242

101 SDS+ Concrete Screw Drills

TAP-CON with 5/16" Hex Shank (SDS+ Shank)

- Industrial Quality
- Carbide Tipped
- Fully Heat-Treated Alloy Steel
- High level of shock resistance allows for heavy duty use



SIZE	PART NUMBER	UPC NUMBER 722170-
5/32" x 5"	101.532.500	10101
5/32" x 7"	101.532.700	10102
3/16" x 5"	101.316.500	10103
3/16" x 7"	101.316.700	10104

UNIT PACK: 1



DRILL BITS – Specialty Bits

103 Concrete Screw Bits

Tang Shank to be used with Jacobs chuck or keyless hammer drills

- Industrial Quality Rotary Hammer Drill Bits
- Carbide Tipped for fast drilling in brick, concrete, tile, and masonry
- Fully Heat-Treated Alloy Steel
- High level of shock resistance allows for heavy duty use

Designed to drill holes for concrete screws. Carbide tip can cut into concrete, brick, or block base material.

LENGTH	SHANK SIZE	PART NUMBER	UPC NUMBER
3-1/2"	5/32"	103.532.350	722170-10301
4-1/2"	5/32"	103.532.450	722170-10302
5-1/2"	5/32"	103.532.550	722170-10303
6-1/2"	5/32"	103.532.650	722170-10304
7-1/2"	5/32"	103.532.750	722170-10305
3-1/2"	3/16"	103.316.350	722170-10306
4-1/2"	3/16"	103.316.450	722170-10307
5-1/2"	3/16"	103.316.550	722170-10308
6-1/2"	3/16"	103.316.650	722170-10309
7-1/2"	3/16"	103.316.750	722170-10310

UNIT PACK: 10



103 Concrete Screw Installation Kit

Contains 1 each: 1/4" Magnetic Nut Setter, 5/16" Magnetic Nut Setter, Phillips Bit Adapter, Drill Bit Adapter, Drive Sleeve, Drill Sleeve, 1/8" Hex Key, #2 Phillips Bit, #3 Phillips Bit

Designed to drill holes for concrete screws. Carbide tip can cut into concrete, brick, or block base material.

NUMBER OF PIECES	PART NUMBER	UPC NUMBER
8	103.TAPKIT	722170-10311



DRILL BITS – Specialty Bits

781 Carbide Tipped Bell Hanger Drills

Available in 4", 6", 12", 18", 24" and 30" overall length

SIZE	SHANK SIZE	PART NUMBER	UPC NUMBER 722170-
3/16" x 4"	3/16"	781.04.0316	78150
1/4" x 4"	1/4"	781.04.0416	78151
5/16" x 4"	5/16"	781.04.0516	78152
3/8" x 4"	3/8"	781.04.0616	78153
7/16" x 4"	3/8"	781.04.0716	78154
1/2" x 4"	7/16"	781.04.0816	78155
1/4" x 6"	1/4"	781.06.0416	78156
3/8" x 6"	3/8"	781.06.0616	78157
1/2" x 6"	7/16"	781.06.0816	78158
5/8" x 6"	1/2"	781.06.1016	78159
3/4" x 6"	1/2"	781.06.1216	78160
7/8" x 6"	1/2"	781.06.1416	78161
1" x 6"	1/2"	781.06.1616	78162
1/4" x 12"	1/4"	781.12.0416	78111
5/16" x 12"	5/16"	781.12.0516	78163
3/8" x 12"	3/8"	781.12.0616	78113
1/2" x 12"	7/16"	781.12.0816	78115
5/8" x 12"	1/2"	781.12.1016	78117
3/4" x 12"	1/2"	781.12.1216	78118
1/4" x 18"	1/4"	781.18.0416	78125
5/16" x 18"	5/16"	781.18.0516	78126
3/8" x 18"	3/8"	781.18.0616	78127
1/2" x 18"	7/16"	781.18.0816	78129
5/8" x 18"	1/2"	781.18.1016	78131
3/4" x 18"	1/2"	781.18.1216	78132
7/8" x 18"	1/2"	781.18.1416	78133
1" x 18"	1/2"	781.18.1616	78134
1/4" x 24"	1/4"	781.24.0416	78139
5/16" x 24"	5/16"	781.24.0516	78164
3/8" x 24"	3/8"	781.24.0616	78141
1/2" x 24"	7/16"	781.24.0816	78142
5/8" x 24"	1/2"	781.24.1016	78143
3/4" x 24"	1/2"	781.24.1216	78144
1/4" x 30"	1/4"	781.30.0416	78165



DRILL HOLES...

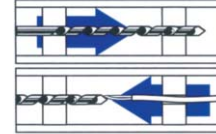

& FISH WIRES

- Carbide tipped
- Fish eye hole for pulling wire
- Packaged
- Heat-Treated High Speed Steel with Black Oxide finish

Carbide tipped masonry drills. Drills for boring masonry fishing wires. Fish eye hole provided near tip of flutes to aid pulling wire after completion of drilling.

DRILL BITS – Specialty Bits

786 Bell Hanger Drills

Available in 12", 18", 24", & 30" overall length

SIZE	SHANK SIZE	PART NUMBER	UPC NUMBER 722170-
1/4" x 12"	1/4"	786.12.0416	78601
5/16" x 12"	5/16"	786.12.0516	78602
3/8" x 12"	3/8"	786.12.0616	78603
7/16" x 12"	7/16"	786.12.0716	78615
1/2" x 12"	3/8"	786.12.0816	78616
9/16" x 12"	3/8"	786.12.0916	78617
5/8" x 12"	7/16" QC	786.12.1016	78618
11/16" x 12"	7/16" QC	786.12.1116	78619
3/4" x 12"	7/16" QC	786.12.1216	78620
3/16" x 18"	3/16"	786.18.0316	78604
1/4" x 18"	1/4"	786.18.0416	78605
5/16" x 18"	5/16"	786.18.0516	78606
3/8" x 18"	3/8"	786.18.0616	78607
7/16" x 18"	3/8"	786.18.0716	78621
1/2" x 18"	3/8"	786.18.0816	78608
9/16" x 18"	3/8"	786.18.0916	78622
5/8" x 18"	7/16" QC	786.18.1016	78623
11/16" x 18"	7/16" QC	786.18.1116	78624
3/4" x 18"	7/16" QC	786.18.1216	78625
13/16" x 18"	7/16" QC	786.18.1316	78626
7/8" x 18"	7/16" QC	786.18.1416	78627
15/16" x 18"	7/16" QC	786.18.1516	78628
1" x 18"	7/16" QC	786.18.1616	78629
1/4" x 24"	1/4"	786.24.0416	78609
5/16" x 24"	5/16"	786.24.0516	78610
3/8" x 24"	3/8"	786.24.0616	78611
1/2" x 24"	3/8"	786.24.0816	78612
1/4" x 30"	1/4"	786.30.0416	78613
3/8" x 30"	3/8"	786.30.0616	78614

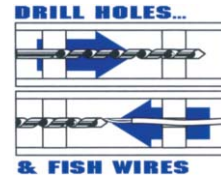

- Heat-Treated High Carbon Steel
- Fish eye hole for pulling wire
- Packaged

82 Deg Point Premium High Carbon Steel Bell Hanger Bit.

High carbon steel drills for boring wood and fishing wires. Fish eye hole provided near tip of flutes to aid pulling wire after completion of drilling.

DRILL BITS – Specialty Bits

FISH-BIT®



777 Fish Bits®

Unique flexible self-feeding bits up to 72" long

SIZE	SHANK SIZE	PART NUMBER	UPC NUMBER 722170-
1/4" x 54"	3/16"	777.54.0416	77701
3/8" x 54"	3/16"	777.54.0616	77703
1/2" x 54"	3/16"	777.54.0816	77705
9/16" x 54"	3/16"	777.54.0916	77707
3/4" x 54"	1/4"	777.54.1216	77709
1" x 54"	1/4"	777.54.1616	77713
1/4" x 72"	3/16"	777.72.0416	77702
3/8" x 72"	3/16"	777.72.0616	77704
1/2" x 72"	3/16"	777.72.0816	77706
9/16" x 72"	3/16"	777.72.0916	77708
3/4" x 72"	1/4"	777.72.1216	77710
1" x 72"	1/4"	777.72.1616	77714
Steering Guide		777.GUIDE	77711

UNIT PACK: 1



Steering Guide



- Flexible shaft
- Drills holes down the length of wall cavities
- Fish eye holes at both ends
- Bulk program available
- Steering guide enables users to direct Fish Bits within a wall cavity
- Heat-Treated High Speed Steel

Unique flexible self feeding bits up to 72" long suitable for drilling holes down the length of wall cavities and through hidden studs with no damage to wall board, plaster or any exterior finish.

A self-feeding screw point and an insulated steering guide helps the operator to start and steer the bit while it is hidden inside the wall cavity.

This bit has a hole at the tip and the shank, which allows you to fish wire inside the wall cavity from either direction after drilling.

DRILL BITS – Specialty Bits

782 Universal Extensions

Lengths from 5-1/2" through 24"

SIZE	SHANK SIZE	PART NUMBER	UPC NUMBER 722170-
1/4" x 12"	1/4"	782.12.0416	78211
1/4" x 18"	1/4"	782.18.0416	78218
5/16" x 12"	5/16"	782.12.0516	78209
5/16" x 18"	5/16"	782.18.0516	78203
5/16" x 24"	5/16"	782.24.0516	78204
7/16" x 5-1/2"	7/16"	782.55.0716	78210
7/16" x 9-1/2"	7/16"	782.95.0716	78205
7/16" x 12"	7/16"	782.12.0716	78206
7/16" x 18"	7/16"	782.18.0716	78207
7/16" x 24"	7/16"	782.24.0716	78208

UNIT PACK: 1

782 Quick Change Extensions

SIZE	SHANK SIZE	PART NUMBER	UPC NUMBER 722170-
1/4" x 6"	1/4"	782.06.0416QC	78213
1/4" x 12"	1/4"	782.12.0416QC	78214
7/16" x 5-1/2"	7/16"	782.55.0716QC	78215
7/16" x 9-1/2"	7/16"	782.95.0716QC	78216
7/16" x 12"	7/16"	782.12.0716QC	78217
7/16" x 18"	7/16"	782.18.0716QC	78219
7/16" x 24"	7/16"	782.24.0716QC	78220

UNIT PACK: 1

625 SDS Extensions

SDS Shank - Fit SDS Drill Chucks,
Receive Standard Arbor Shanks

SIZE	SHANK SIZE	PART NUMBER	UPC NUMBER 722170-
3/8" x 9-1/2"	3/8"SDS	625.95.0616	62578
7/16" x 9-1/2"	3/8"SDS	625.95.0716	62579

UNIT PACK: 1

782.12.0816 Extension

SIZE	SHANK SIZE	PART NUMBER	UPC NUMBER 722170-
12" x 12"	1/2"	782.12.0816	78221



- Provided with 2 set screws and hex wrench
- Fits most boring tools with 1/4", 5/16", and 7/16" hex shanks

To allow the head of the extensions to pass through the hole being bored:

- 1/4" extensions require bits 1/2" or larger
- 5/16" extensions require bits 5/8" or larger
- 7/16" extensions require bits 7/8" or larger
- Spring loaded for one-handed loading and unloading of Quick Change bits.

HOLE SAWS

- Steel Alloy body with COBALT steel teeth
- 1-1/2" Depth cuts through 2" x 4" in one easy pass.
- 4/6 Variable Pitch Tooth combination, reduces vibration...Increases productivity.
- Side Cutouts for instant chip, plug, and heat removal
- Tough 3/16" Thick Back Plate
- Faster cutting...More Holes per Saw

Bi-Metal Vari-Pitch 4/6TPI, 1-1/2" Depth

PART#	DIAMETER		UPC NUMBER 722170-	PIPE ENTRY SIZE	PIPE TAP SIZE
	INCH	MM			
624.0916	9/16"	14	62401		
624.1016	5/8"	16	62402		
624.1116	11/16"	17	62403		
624.1216	3/4"	19	62404	3/8"	
624.1316	13/16"	21	62405		
624.1416	7/8"	22	62406	1/2"	3/4"
624.1516	15/16"	24	62407		
624.1616	1"	25	62408		
624.1716	1-1/16"	27	62409		
624.1816	1-1/8"	29	62410	3/4"	1"
624.1916	1-3/16"	30	62411		
624.2016	1-1/4"	32	62412		
624.2116	1-5/16"	33	62413		
624.2216	1-3/8"	35	62414	1"	
624.2316	1-7/16"	37	62415		
624.2416	1-1/2"	38	62416		1-1/4"
624.2516	1-9/16"	40	62417		
624.2616	1-5/8"	41	62418		
624.2716	1-11/16"	43	62419		
624.2816	1-3/4"	44	62420	1-1/4"	1-1/2"
624.2916	1-13/16"	46	62421		
624.3016	1-7/8"	48	62422		
624.3216	2"	51	62423	1-1/2"	
624.3316	2-1/16"	52	62424		
624.3416	2-1/8"	54	62425		
624.3616	2-1/4"	57	62426		2"
624.3716	2-5/16"	59	62427		
624.3816	2-3/8"	60	62428		
624.4016	2-1/2"	64	62429	2"	
624.4116	2-9/16"	65	62430		
624.4216	2-5/8"	67	62431		2-1/2"
624.4416	2-3/4"	70	62432		
624.4616	2-7/8"	73	62433		
624.4816	3"	76	62434	2-1/2"	
624.5016	3-1/8"	79	62435		3"
624.5216	3-1/4"	83	62436		
624.5416	3-3/8"	86	62437		
624.5616	3-1/2"	89	62438		
624.5816	3-5/8"	92	62439	3"	
624.6016	3-3/4"	94	62440		3-1/2"
624.6216	3-7/8"	98	62441		
624.6416	4"	102	62442		
624.6616	4-1/8"	105	62443	3-1/2"	
624.6816	4-1/4"	108	62444		
624.7016	4-3/8"	111	62445		
624.7216	4-1/2"	114	62446	4"	
624.7616	4-3/4"	121	62447		4-1/2"
624.8016	5"	127	62448		
624.8416	5-1/4"	133	62452		
624.8816	5-1/2"	140	62449		
624.9216	5-3/4"	146	62450		
624.9616	6"	152	62451		



UNIT PACK: 1 PER BOX

HOLE SAWS

Recommended Hole Saw Speeds in RPM

PART# 624.	DIAMETER		MILD STEEL	TOOL & STAINLESS			
	INCH	MM		STEELS	CAST IRON	BRASS	ALUMINUM
0916	9/16"	14	550	300	400	790	900
1016	5/8"	16	530	275	365	730	825
1116	11/16"	17	500	250	330	665	750
1216	3/4"	19	460	230	300	600	690
1316	13/16"	21	425	210	280	560	630
1416	7/8"	22	390	195	260	520	585
1516	15/16"	24	370	185	245	495	555
1616	1"	25	350	175	235	470	525
1716	1-1/16"	27	325	160	215	435	480
1816	1-1/8"	29	300	150	200	400	450
1916	1-3/16"	30	285	145	190	380	425
2016	1-1/4"	32	275	140	180	360	410
2116	1-5/16"	33	260	135	175	345	390
2216	1-3/8"	35	250	125	165	330	375
2316	1-7/16"	37	240	120	160	315	360
2416	1-1/2"	38	230	115	150	300	345
2516	1-9/16"	40	220	110	145	290	330
2616	1-5/8"	41	210	150	140	280	315
2716	1-11/16"	43	205	100	135	270	305
2816	1-3/4"	44	195	95	130	260	295
2916	1-13/16"	46	190	95	125	250	285
3016	1-7/8"	48	180	90	120	240	270
3216	2"	51	170	85	115	230	255
3316	2-1/16"	52	165	80	110	220	245
3416	2-1/8"	54	160	80	105	210	240
3616	2-1/4"	57	150	75	100	200	230
3716	2-5/16"	59	145	75	100	195	225
3816	2-3/8"	60	140	70	95	190	220
4016	2-1/2"	64	135	70	90	180	205
4116	2-9/16"	65	130	65	85	175	200
4216	2-5/8"	67	130	65	85	170	195
4416	2-3/4"	70	125	60	80	160	185
4616	2-7/8"	73	120	60	80	160	180
4816	3"	76	115	55	75	150	170
5016	3-1/8"	79	110	55	70	145	165
5216	3-1/4"	83	105	50	70	140	155
5416	3-3/8"	86	100	50	65	130	150
5616	3-1/2"	89	95	45	65	125	145
5816	3-5/8"	92	95	45	60	120	140
6016	3-3/4"	94	90	45	60	120	135
6216	3-7/8"	98	90	45	60	115	130
6416	4"	102	85	40	55	115	125
6616	4-1/8"	105	85	40	55	110	120
6816	4-1/4"	108	80	40	55	110	115
7016	4-3/8"	111	80	40	50	100	110
7216	4-1/2"	114	75	35	50	100	105
7616	4-3/4"	121	70	35	45	90	95
8016	5"	127	65	30	40	85	90
8416	5-1/4"	133	60	30	35	80	85
8816	5-1/2"	140	60	30	35	80	85
9216	5-3/4"	146	55	25	35	75	80
9616	6"	152	55	25	35	75	80



! When drilling metals,
use a cutting compound
such as MAG-LUBE
concentrated cutting fluid.

HOLE SAWS

624 Bi-Metal Hole Saw Kits

Cuts holes in wood, plastic, pipe, stainless steel, or any machinable metal, including nail-embedded wood and plywood.

PART#	HOLE SAW KIT624.	UPC # 722170-
Industrial Maintenance Hole Saw Kit	9114	62464
Electrician's Hole Saw Kit	9108	62465
Plumber's Hole Saw Kit	9308	62466
Master Electrician's Hole Saw Kit	9116	62467



Electrician's Kit MAG 624.9108

Contains 1 each: 7/8", 1-1/8", 1-3/8", 1-3/4", 2", 2-1/2"

Arbors: 1/4" QC, 7/16", 1/4" pilot bit



Industrial / Maintenance Kit MAG 624.9114

Contains 1 each: 3/4", 7/8", 1-1/8", 1-3/8", 1-1/2", 1-3/4", 2", 2-1/4", 2-1/2"

Arbors: 1/4" QC, 7/16", adapter, 1/4" pilot bit



Plumber's Kit MAG 624.9308

Contains 1 each: 3/4", 7/8", 1-1/8", 1-1/2", 1-3/4", 2-1/4"

Arbors: 1/4" QC, 7/16", 1/4" pilot bit



Master Electrician's Kit MAG 624.9116

Contains 1 each: 7/8", 1-1/8", 1-3/8", 1-1/2", 1-3/4", 2", 2-1/2", 3", 3-5/8", 4-1/8", 4-1/2"

Arbors: 7/16", 3/8" Hex, 1/4" QC, 4" pilot drill, 12" extension
Conduit entrance sizes from 1/2" - 4"

625 Hole Saws & Kits

625 Carbide Grit Hole Saws

1-1/2" Depth

SIZE	PART NUMBER	UPC NUMBER
3/4"	625.1216	62504
7/8"	625.1416	62506
1"	625.1616	62508
1-1/8"	625.1816	62510
1-1/4"	625.2016	62512
1-3/8"	625.2216	62514
1-1/2"	625.2416	62516
1-3/4"	625.2816	62520
2"	625.3216	62523
2-1/8"	625.3416	62525
2-1/4"	625.3616	62526
2-3/8"	625.3816	62528
2-1/2"	625.4016	62529
3"	625.4816	62534
3-5/8"	625.5816	62538
4"	625.6416	62542
4-1/8"	625.6616	62543
625 Carbide Grit Kits		
Electricians Kit	625.9108	62565
Plumbers Kit	625.9308	62566

- Steel Alloy backing and body
- Works in rotary and SDS Hammer mode
- Works forward and reverse
- Use standard or SDS shank arbors
- Carbide Grit cutting edge and side cutouts for instant chip, plug, and heat removal

Cuts tile, brick, concrete block, fiber cement siding & backer board, stucco, old plaster. Concrete pavers. Diameters 3/4" through 4-1/8". Works in rotary and SDS Hammer mode. Works forward and reverse.



625 Carbide Grit Hole Saws Kit

MAG 625.9108 Electrician's Kit

Contains 1 each: 7/8", 1-1/8", 1-3/8", 1-3/4", 2", 2-1/2"
Arbors: 625.9005, 625.9002, 1/4" pilot bit

MAG 625.9308 Plumber's Kit

Contains 1 each: 3/4", 7/8", 1-1/8", 1-1/2", 1-3/4", 2-1/4"
Arbors: 625.9005, 625.9002, 1/4" pilot bit



HOLE SAWS

625 Canlight Hole Saw

PART #	INCH	DIAMETER		UPC NUMBER
		MM	DECIMAL (IN)	722170-
625.0058	3-5/8"	92	3.625	62580
625.0068	4-1/4"	108	4.25	62581
625.0070	4-3/8"	111	4.375	62582
625.0088	5-1/2"	140	5.5	62583
625.0102	6-3/8"	162	6.375	62584
625.0106	6-5/8"	168	6.625	62585
625.0110	6-7/8"	175	6.875	62586
625-DB (DUST BOWL)				62587



625 CANLIGHT HOLE SAW

- Perfect for drilling in drywall, plaster, wood, acoustical tile, ceiling tile, stucco, plastic, fiber cement and sheet metal when installing recess lights
- TUNGSTEN Carbide Grit Edge reduces dust and increases durability by making the hole saw not catch onto the cutting surface
- Continuous cutting teeth reduces vibration and improves cutting performance for a stronger and longer lasting hole saw
- OPEN Ended backing design makes plug removal easy and efficient while creating a fast instant start to the next hole
- Compatible with standard 5/8"-18 thread ARBORS with 2 pin mounts
- Cuts up to 1-1/2" deep



625-DB DUST BOWL

- Prevents overdrilling and makes drilling safer & cleaner
- HEAVY DUTY & Flexible silicone rubber material has high wear and heat resistance. Cleanly sticks to the ceiling without leaving a single mark
- Large opening with a metal ring fits all standard drill chucks and makes the dust bowl last longer
- Collects dust and debris to prevent dust from falling onto the user while drilling

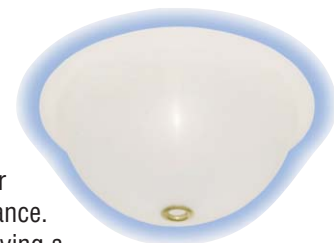

626 Hole Cutters

626 Tungsten Carbide Tipped Hole Cutters

SIZE	SHANK DIA IN	PART NUMBER	UPC NUMBER 722170-
11/16"	7/16"	626.1116	62603
3/4"	7/16"	626.1216	62604
7/8"	7/16"	626.1416	62606
1"	7/16"	626.1616	62608
1-1/16"	7/16"	626.1716	62609
1-1/8"	7/16"	626.1816	62610
1-3/16"	7/16"	626.1916	62611
1-1/4"	7/16"	626.2016	62612
1-5/16"	7/16"	626.2116	62613
1-3/8"	7/16"	626.2216	62614
1-7/16"	7/16"	626.2316	62615
1-1/2"	7/16"	626.2416	62616
1-3/4"	7/16"	626.2816	62620
2"	7/16"	626.3216	62623
2-1/8"	7/16"	626.3416	62625
2-1/4"	7/16"	626.3616	62626
2-3/8"	1/2"	626.3816	62628
2-1/2"	1/2"	626.4016	62629
2-5/8"	1/2"	626.4216	62631
2-3/4"	1/2"	626.4416	62632
3"	1/2"	626.4816	62634
CT pilot bit	1/4"	626.9015B	62663
CT Kit 1		626.KIT1	62662
CT Kit 2		626.KIT2	62663



- Heat-Treated Steel Alloy material
- Cuts up to 7/16" deep holes
- Built-in pilot drill and ejecting spring self centers the hole saw and instantly removes plug and debris for fast and clean cuts
- Tungsten Carbide Tipped cutting teeth
- HEX Shank with 3 Flats

Diameters 11/16" through 3". Cuts sheet metal, stainless steel, iron, cast iron, copper, abrasive materials such as high density resin and metal plate. Cuts up to 3/16" deep. Auto ejecting slug.

626 Hole Cutter Kits

Tungsten Carbide Tipped Hole Cutter Kit 1



626.KIT1

Contains 1 each: 7/8", 1-1/8", 1-3/8", 626.9015B pilot bit, ejector spring and a hex wrench
Cutters in the kit provide conduit entry for 1/2", 3/4" and 1" conduit.

Tungsten Carbide Tipped Hole Cutter Kit 2



626.KIT2

Contains 1 each: 7/8", 1-1/8", 1-3/8", 1-3/4", 2", 2-1/2", 2 spare 626.9015B pilot bits, 2 ejector springs and a hex wrench.
Cutters in the kit provide conduit entry for 1/2", 3/4", 1", 1-1/4", 1-1/2" and 2" conduit.

HOLE SAWS

628 Carbide Tipped Hole Saws

- Carbide Tipped teeth for cutting hard metals such as stainless steel, iron, copper, brass
- 1-3/8" Cutting Depth

- Side cutouts for instant chip, plug, and heat removal
- Tough 3/16" Thick Back Plate
- Faster cutting...More Holes per Saw

Carbide Tipped Vari-Pitch 3TPI

PART#	DIAMETER		UPC NUMBER 722170-
	INCH	MM	
628.1216	3/4"	19	62804
628.1316	13/16"	21	62805
628.1416	7/8"	22	62806
628.1516	15/16"	24	62807
628.1616	1"	25	62808
628.1816	1-1/8"	29	62810
628.2016	1-1/4"	32	62812
628.2216	1-3/8"	35	62813
628.2416	1-1/2"	38	62815
628.2616	1-5/8"	41	62817
628.2816	1-3/4"	44	62819
628.3016	1-7/8"	48	62821
628.3216	2"	51	62822
628.3416	2-1/8"	54	62824
628.3616	2-1/4"	57	62825
628.3816	2-3/8"	60	62827
628.4016	2-1/2"	64	62828
628.4216	2-5/8"	67	62830
628.4416	2-3/4"	70	62831
628.4616	2-7/8"	73	62832
628.4816	3"	76	62833
628.5016	3-1/8"	79	62834
628.5216	3-1/4"	83	62835
628.5416	3-3/8"	86	62836
628.5616	3-1/2"	89	62837
628.5816	3-5/8"	92	62838
628.6016	3-3/4"	94	62839
628.6216	3-7/8"	98	62840
628.6416	4"	102	62841
628.6616	4-1/8"	105	62842
628.6816	4-1/4"	108	62843
628.7016	4-3/8"	111	62844
628.7216	4-1/2"	114	62845
628.7616	4-3/4"	121	62846
628.8016	5"	127	62847
628.8416	5-1/4"	133	62848
628.8816	5-1/2"	140	62849
628.9216	5-3/4"	146	62850
628.9616	6"	152	62851

UNIT PACK: 1 PER BOX



Carbide Tipped Hole Saw is perfect for cutting stainless steel, iron, brass, copper, wood, fiberglass, and composites

624 & 625 SDS Arbors/Pilot Bits

Arbors



Pilot Bits



Pilot bits sold in packages of 2, 15, & 35 ea.



Springs sold in packages of 5

 When drilling metals, use a cutting compound such as MAG-LUBE *concentrated cutting fluid*.

625 SDS Arbors/Pilot Bits

PART NUMBER	ARBOR SHANK	DESCRIPTION	UPC NUMBER 722170-
625.9002	3/8" SDS Plus	Fits hole saws 1-1/4" and up	62573
625.9005	3/8" SDS Plus	Fits hole saws up to 1-3/16"	62572
625.9015B	1/4" with 3 Flats	3-1/8" Carbide Tipped Pilot Drill	62574

624 Arbors / Pilot Bits

PART NUMBER	ARBOR SHANK	APPLICATIONS	UPC NUMBER 722170-
624.9002	7/16" Hex Positive Grip	5/8"-18 thread-fits saws 1-1/4" & up	62458
624.9004	3/8" Hex	5/8"-18 thread-fits saws 1-1/4" & up	62459
624.9007	3/8" Hex	1/2"-20 thread-fits saws up to 1-3/16"	62460
624.9005	1/4" Hex	1/2"-20 thread-fits saws up to 1-3/16"	62457
624.9009	7/16" Hex	1/2"-20 thread-fits saws up to 1-3/16"	62471
624.9014B	4" Pilot Bit HSS	All Arbors	62461
624.9015B	3" Pilot Bit HSS	All Arbors	62462
624.9080AD	Adapter	9005-9007	62463
624.9010	Ejector Springs		62472

HOLE SAWS

629 Thin Wall Hole Saw

Cuts up to 3/8" deep

	DIAMETER			UPC NUMBER
629.1216	3/4"	19	0.75	62904
629.1416	7/8"	22	0.875	62906
629.1616	1"	25	1	62908
629.1816	1-1/8"	29	1.125	62910
629.2016	1-1/4"	32	1.25	62912
629.2216	1-3/8"	35	1.375	62914
629.2416	1-1/2"	38	1.5	62916
629.KIT1	7/8", 1-1/8", 1-3/8"			62962

- Perfect for drilling in thin metal and plastic/PVC pipes with a impact driver machine
- Heavy duty shatterproof, heat-treated Steel Alloy backing absorbs shocks and vibrations for a stronger and longer lasting hole saw
- Stop shoulder prevents overdrilling and doesn't allow the hole saw to go too deep into the cutting surface
- Ejector spring on the tip instantly removes plug and debris while drilling
- Heavy Duty electron welded cobalt steel cutting teeth with 8TPI
- 1/4" Quick Change Hex Shank for a tight firm grip with drill chucks and instant changing of the hole saw













RECIPROCATING SAWS

732 Bi-Metal Reciprocating Saw Blades

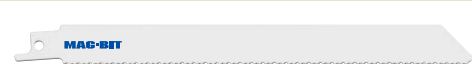
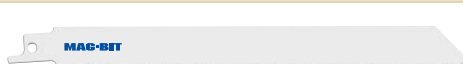
Bi-Metal (Universal Tang 1/2" Shank fits all RECIP saw machines) Blades

- Shatter & Shock resistant spring steel alloy backing for a stronger and longer lasting blade. Extra flexibility allows extra vibrations to be absorbed
- Welded COBALT Steel cutting teeth makes clean and fast cuts
- MAGBIT unique teeth setting pattern instantly removes debris and cools the blade

BLADE SHAPE	APPLICATIONS	PART# 732.	OAL x H x T	TPI	UPC # 722170-
	For thick and thin metals. Very fast cuts in metal, sheet metal, pipes, non-ferrous metal, stainless steel, plastics, fiberglass.	123T	6" x 3/4" x .035	Prog	73220
	Fast, straight cuts in thin material. Sheet metal.	418T	4" x 3/4" x .035	18	73205
	Tear-free cuts in plasterboard, drywall. Plunge cuts.	600V	6" x 3/4" x .050	6V-Tooth	73221
	Wood with nail/metal, sheet metal, pipes, aluminum profiles, pallets.	610T	6" x 3/4" x .035	10	73215
	Metal, non-ferrous metal, aluminum, sheet metal, pipes and profiles.	614T	6" x 3/4" x .035	14	73202
	Fast, straight cuts in thin material. Sheet metal.	618T	6" x 3/4" x .035	18	73206
	Fast, straight cuts in thin material. Sheet metal.	624T	6" x 3/4" x .035	24	73210
	Wood with nails/metal, sheet metal, aluminum pipes and profiles	810T	8" x 3/4" x .035	10	73216
	Thick sheet metal, solid pipes/profiles, fast cut.	814T	8" x 3/4" x .035	14	73203
	Fast, straight cuts in thin material. Sheet metal.	818T	8" x 3/4" x .035	18	73207
	Wood with nails/metal, sheet metal, aluminum profiles, plastic profiles.	1210/14T	12" x 3/4" x .035	10/14	73281
	Fast, straight cuts in thin material. Sheet metal.	1218T	12" x 3/4" x .035	18	73208







Sold in units: 5 pack, bulk 50 pack

RECIPROCATING SAWS

732 "Salvage" Heavy Duty Metal Cutting Demolition Blades

Bi-Metal (Universal Tang 1/2" Shank fits all RECIP saw machines) Blades

- Shatter & Shock resistant spring steel alloy backing for a stronger and longer lasting blade. Extra flexibility allows extra vibrations to be absorbed
- Welded COBALT Steel cutting teeth makes clean and fast cuts
- MAGBIT unique teeth setting pattern instantly removes debris and cools the blade

BLADE SHAPE	APPLICATIONS	PART# 732.	OAL x H x T	TPI	UPC # 722170-
	Demolition blade thick body for less vibration. Variable gullet, depth for faster chip removal.	610/14HT	6" x 3/4" x .050	10/14	73222
	Demolition blade thick body for less vibration. Variable gullet, depth for faster chip removal.	810/14HT	8" x 3/4" x .050	10/14	73223
	Demolition blade thick body for less vibration.	818HT	8" x 3/4" x .050	18	73224
	Demolition blade thick body for less vibration. Variable gullet, depth for faster chip removal.	1210/14HT	12" x 3/4" x .050	10/14	73204
	Demolition blade thick body for less vibration.	609HVV	6" x 7/8" x .062	8/10	73225
	Demolition blade thick body for less vibration.	909HVV	9" x 7/8" x .062	8/10	73226

Sold in units: 5 pack, bulk 50 pack. (732.609HVV & 732.909HVV bulk 40 pack)

732 "RAZER" Heavy Duty Wood Cutting Demolition Blades

Bi-Metal (Universal Tang 1/2" Shank first all RECIP saw machines) Blades

- Shatter & Shock resistant spring steel alloy backing for a stronger and longer lasting blade. Extra flexibility allows extra vibrations to be absorbed
- Welded COBALT Steel cutting teeth makes clean and fast cuts
- MAGBIT unique teeth setting pattern instantly removes debris and cools the blade

BLADE SHAPE	APPLICATIONS	PART# 732.	OAL x H x T	TPI	UPC # 722170-
	Hard and soft wood, particleboard, plywood, wood with nails, plastic.	65/8HVV*	6" x 7/8" x 0.63	5/8	73268
	Hard and soft wood, particleboard, plywood, wood with nails, plastic.	95/8HVV*	9" x 7/8" x .063	5/8	73269
	Hard and soft wood, particleboard, plywood, wood with nails, plastic.	125/8HVV*	12" x 7/8" x .063	5/8	73270

Sold in units: 5 pack, bulk 25 pack

*Replaces 6TPI model

RECIPROCATING SAWS

732 Heavy Duty Wood Cutting Blades

Bi-Metal (Universal Tang 1/2" Shank fits all RECIP saw machines) Blades

- Shatter & Shock resistant spring steel alloy backing for a stronger and longer lasting blade. Extra flexibility allows extra vibrations to be absorbed
- Welded COBALT Steel cutting teeth makes clean and fast cuts
- MAGBIT unique teeth setting pattern instantly removes debris and cools the blade

BLADE SHAPE	APPLICATIONS	PART# 732.	OAL x H x T	TPI	UPC # 722170-
	Wood with nails, chipboard, plastic, fiberglass, window frames, wood+metal, solid woods, excellent for plunge cuts.	65/8T*	6" x 3/4" x .050	5/8	73259
	Wood with nails/metal, chipboard, plastic profiles, fiberglass, solid woods.	95/8T*	9" x 3/4" x .050	5/8	73260
	Wood with nails/metal, chipboard, aerated concrete, plastics, fiberglass.	125/8T*	12" x 3/4" x .050	5/8	73261







Sold in units: 5 pack, bulk 50 pack

*Replaces 6TPI model

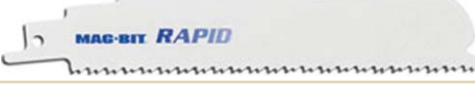
732 "RAPID" Fast Metal Cutting Blades

Bi-Metal (Universal Tang 1/2" Shank fits all RECIP saw machines) Blades

- Shatter & Shock resistant spring steel alloy backing for a stronger and longer lasting blade. Extra flexibility allows extra vibrations to be absorbed
- Welded COBALT Steel cutting teeth makes clean and fast cuts
- MAGBIT unique teeth setting pattern instantly removes debris and cools the blade

BLADE SHAPE	APPLICATIONS	PART# 732.	OAL x H x T	TPI	UPC # 722170-
	20% faster rough cuts in metal pipe, channels, tubing, angle iron up to 4". Steel, wood with nails.	68/10T	6" x 1" x .043	8/10	73262
	20% faster rough cuts in metal pipe, channels, tubing, angle iron up to 4". Steel, wood with nails.	98/10T	9" x 1" x .043	8/10	73263
	20% faster rough cuts in metal pipe, channels, tubing, angle iron up to 4". Steel, wood with nails.	128/10T	12" x 1" x .043	8/10	73264
	20% faster rough cuts in metal pipe channels, tubing, angle iron up to 4". Rescue model.	614/18T	6" x 1" x .043	14/18	73265
	20% faster rough cuts in metal pipe channels, tubing, angle iron up to 4". Rescue model.	914/18T	9" x 1" x .043	14/18	73266
	20% faster rough cuts in metal pipe channels, tubing, angle iron up to 4". Rescue model.	1214/18T	12" x 1" x .043	14/18	73267



Sold in units: 5 pack, bulk 25 pack

RECIPROCATING SAWS

732 Scroll Blades

Bi-Metal (Universal Tang 1/2" Shank first all RECIP saw machines) Blades

- Shatter & Shock resistant spring steel alloy backing for a stronger and longer lasting blade. Extra flexibility allows extra vibrations to be absorbed
- Welded COBALT Steel cutting teeth makes clean and fast cuts
- MAGBIT unique teeth setting pattern instantly removes debris and cools the blade
- Scroll SHAPE is perfect for cuts in tight, small spaces by having a large tapered section



BLADE SHAPE	APPLICATIONS	PART# 732.	OAL x H x T	TPI	UPC # 722170-
	Scroll cuts in metal.	418STPI	4" x 1/4" x 0.35	18	73227
	Scroll cuts in wood.	606STPI	6" x 1/2" x .050	6	73228

Sold in units: 5 pack, bulk 50 pack

732 Carbide Grit Reciprocating Saw Blades

Bi-Metal (1/2" Shank) Blades

- Continuous Carbide Grit cutting edge cuts fiber cement, brick, ceramics, cast iron, fiberglass, laminates, composites, plastic, limestone, carbon fiber, kevlar, honeycomb
- Faster cutting and longer lasting in independent testing.
- Shatter & Shock resistant spring steel alloy backing for a stronger and longer lasting blade. Extra flexibility allows extra vibrations to be absorbed

BLADE SHAPE	APPLICATIONS	PART# 732.	OAL x H x T	UPC # 722170-
	Cuts fiber cement, kevlar, brick, ceramic tile, laminates, composites, fiberglass, cast iron, limestone.	600CG	6"	73229
	Cuts fiber cement, kevlar, brick, ceramic tile, laminates, composites, fiberglass, cast iron, limestone.	800CG	8"	73323

Sold in units: 5 pack, bulk 40 pack

Mag-Bit Hand Tools

801 Tube Cutter

SIZE CUT	MATERIAL CUT	PART NUMBER	UPC NUMBER 722170-
1/8"-1-1/4"	Copper/EMT	801.114C	80101
1/4"-1-1/2"	Copper/EMT	801.112C	80103
1/8"-1-5/8"	Copper/EMT	801.158C	80105
1/4"-2-5/8"	Copper/EMT/Plastic	801.258C	80107
	Copper/EMT Wheel	801.114CW*	80110
	Stainless Wheel	801.114SW*	80111
	Copper/EMT Wheel	801.112CW*	80112
	Stainless Wheel	801.112SW*	80113
	Copper/EMT Wheel	801.158CW*	80114
	Stainless Wheel	801.158SW*	80115
	Copper/EMT Wheel	801.258CW*	80116
	Stainless Wheel	801.258SW*	80117
	Plastics Wheel	801.258PW*	80118

*Priced each-sold in packs of 2 each

- Cuts Copper/EMT, Stainless steel & pvc.
- Interchangeable cutting wheels
- Spare cutting wheel in handle
- Deburring tool built in
- Cut size from 1/8"-2-5/8"

Clean cuts in Copper/EMT, Stainless Steel and PVC. Interchangeable cutting wheels. Will not thread. Heavy twist knob easy to use with gloves. Spare Rotary Tube Cutter Replacement Wheels in Handles. Each comes with a deburring tool built in. Cuts tube from 1/8" diameter through 2-5/8" diameter.



Spare Rotary Tube Cutter Replacement Wheels



801 Copper/EMT Wheels



Stainless Steel Wheels



801 Plastic Wheels

801 Mini Tube Cutter

SIZE CUT	MATERIAL CUT	PART NUMBER	UPC NUMBER 722170-
1/8"-1-1/8"	Copper/EMT, Plastic	801.118C	80119



- Cuts Copper/EMT, Stainless and PVC.
- Cuts Diameters from 1/8" through 1-1/8".
- Small enough to use in tight spaces.
- Fits easily in any tool chest or even your pocket.

HAND TOOLS

Mag-Bit Hand Tools

801 Auto Tube Cutter

SIZE CUT	MATERIAL CUT	PART NUMBER	UPC NUMBER 722170-
1/2"	Copper, Plastic	801.0816A	80121
3/4"	Copper, Plastic	801.1216A	80122



801.0816A



801.1216A

- Auto tube cutter automatically tightens and cuts as you turn it around the tube.
- No protruding handle makes it very compact.
- Cuts Copper.
- Each tool fits one size of pipe.
- Replacement cutting wheel part number 801.114CW

111 Mag-Measure

25' Tape

SIZE	INCH MM	PART NUMBER	UPC NUMBER 722170-
25' long		111.4608N*	11101

*Priced each-sold 12 per display case



- Super stiff tape
- Thumb lock
- 25 feet long
- Ergonomic rubber case

Thumb lock keeps tape from snapping back. Finger brake under return slot protects returning tape by controlling speed. 25 feet long. Ergonomic rubber case.

303DLX File

OAL	PART NUMBER	UPC # 722170
7"	303DLX.FILE	30318



- Specially designed to sharpen your valuable auger bits for longer cutting life.
- Safe Edge is a filed end for sharpening drill bits
- Single Cut Edge is a pick sharp end

901 Mag-Lube Concentrated Cutting Fluid

FOR USE WITH MAG-	PART NUMBER	UPC NUMBER 722170-
Saw, Shark-Bit, Long Boy, Step Drills, and Silver & Deming bits when cutting metals.	901-LUBE	90101

Sold in point-of-purchase 12 pack display. Contains 12 bottles, each 2 ounces which can be diluted with water to make 1.56 gallons of cutting fluid.

- Tapping, drilling & sawing @ 20:1 dilution.
- Spray mist applications @ 20:1 dilution.
- Grinding @ 20:1 dilution.
- Turning, milling, threading & cutting @ 20:1 dilution.



- Highly concentrated, recommended dilution 1 part MAG-LUBE to 20 parts water.
- Excellent rust control on all metals: No in-process rust or rework.
- Low foaming, low misting. Water soluble.
- Non-nitrited, non-halogenated, non-silicone or silicate, non-phenolic.
- Rated insignificant under N.F.P.A. hazard rating for both fire and health.

Applications: Sawing, Drilling, Cutting, Tapping, Milling, Grinding, Reaming, Turning. Materials: All metals (except magnesium) Fiberglass, Composites, Ceramics, Quartz, Glass and Ferrite.

425 Hand Hack Saw Frame

Heavy Duty Hack Saw with Blade

BLADE / FRAME SHAPE	APPLICATIONS	PART#	UPC # 722170-
	<ul style="list-style-type: none"> • Heavy duty cast aluminum handle • Very high blade tension • 45° heat treated mounting pins for flush cuts • Stores up to ten blades in rectangular steel cross bar • Also works as a jab or compass saw 	425.0001	42506

UNIT PACK: 1 FRAME WITH BLADE

425 Hand Hack Saw Blades

Bi-Metal Blades

BLADE SHAPE	APPLICATIONS	PART#	OAL-TPI	UPC NUMBER 722170-
	Pipe tubing and solids. Cuts wood, plastic or any machinable metal; including conduit, stainless steel tubing, angle iron, copper tubing, and structural materials.	425.1218	12" - 18TPI	42503
		425.1224	12" - 24TPI	42504
		425.1232	12" - 32TPI	42505

UNIT PACK: 10

425 Mini Hand Hack Saw Frame

Heavy Duty Hack Saw with Blade

BLADE / FRAME SHAPE	APPLICATIONS	PART#	UPC # 722170-
	For use in tight and hard to reach locations.	425.0002	42507

UNIT PACK: 1 FRAME WITH BLADE

425 Mini Hand Hack Saw Blades

Bi-Metal Blades

BLADE SHAPE	APPLICATIONS	PART#	OAL-TPI	UPC NUMBER 722170-
	Pipe tubing and solids. Cuts wood, plastic or any machinable metal; including conduit, stainless steel tubing, angle iron, copper tubing, and structural materials.	425.532T	5" - 32TPI	42508

UNIT PACK: 5

HAND TOOLS

600 & 700 Drywall Saw

Heavy Duty Drywall Saw

BLADE SHAPE	APPLICATIONS	PART#	UPC # 722170-
	<ul style="list-style-type: none"> • 6" Heavy duty drywall saw for cutting: wallboard, plywood & plastics. • Fully sharpened teeth for quick clean start. • Extra heavy duty blade. Stronger, less flexible. • Impulse hardened precision ground teeth. 	600.0001	60001
 • Ergonomic Soft Rubber Triangle Handle.		700.0001	70001

UNIT PACK: 1

800 Heavy Duty PVC Saw

OAL LENGTH	PART NUMBER	UPC NUMBER 722170-
12" Saw	800.120S	80001
18" Saw	800.180S	80002
12" Blade	800.120B	80003
18" Blade	800.180B	80004



- Cuts PVC, CPVC and ABS.
- Blades cut both directions for easy starts.
- Sturdy cast aluminum handle.

Cuts electrical conduit, plastic drainage, pipe suitable for irrigation system installation. Sturdy cast aluminum handle, large enough to fit a hand with a work glove. Accepts 13" long and 18" long blades. Replacement blades available. Blades cut in both directions for easy starts. Cuts PVC, CPVC and ABS. Cuts drain pipe, electrical conduit & sprinkler pipe. Cuts wood. Cuts in both directions for easy starts!

800 Heavy Duty Ratcheting Pipe Cutter

DIAMETER SIZE	PART NUMBER	UPC NUMBER 722170-
1-5/8"	800.158PC	80005



- Contractor Grade
- Cuts up to 1-5/8"
- Chrome plated parts
- Aluminum alloy body

Cuts PVC, rubber, and vinyl tubing up to 1-5/8" outer diameter. Precision ground blade cuts straighter and smoother. Aluminum alloy body, light weight and durable. Chrome plated parts to prevent rust. Satisfaction guaranteed.

480 Anchor Kits

- Includes anchors, screws, and a drill bit

Ribbed Anchor Kit contains 100 Ribbed Anchors, 100 #10 x 1" 3 Way Screws, and a 1/4" Masonry Drill Bit.

Conical Anchor Kit contains 100 Conical Anchors, 100 #10 x 1" 3 Way Screws, and a 1/4" Masonry Drill Bit.

EZ Nylon Anchor Kit contains 50 Nylon Anchors, 50 Phillips Screws, and a #2 x 1" Phillips Insert Bit.

EZ Zinc Anchor Kit contains 50 Zinc Anchors, 50 Phillips Screws, and a #2 x 1" Phillips Insert Bit.

3 Way Screw has a single head for a Hex, Slot, or a Phillips Screwdriver

DESCRIPTION	PART NUMBER	UPC NUMBER 722170-
Ribbed Anchor Kit	480.6000RAS	48001
Conical Anchor Kit	480.6001CAS	48002
EZ Nylon Anchor Kit	480.6010NAS	48003
EZ Zinc Anchor Kit	480.6015ZAS	48004



Ribbed Anchor Kit
480.6000RAS

Conical Anchor Kit
480.6001CAS

EZ Nylon Anchor Kit
480.6010NAS

EZ Zinc Anchor Kit
480.6015ZAS

111 Cable Ties



- MADE IN USA
- Self locking pawl with a low profile head for extra snag resistance
- Reinforced pawl and serrated edges create a smooth pull thru action and a stronger grip

- Works in a temperature range of -40°F to 185°F
- Indoor use for various applications
- 100% heavy duty nylon provides high tensile strength
- High tensile strength with low insertion force
- Ideal for many industries

DESCRIPTION	PART NUMBER	UPC NUMBER 722170-
4" Length, 18# Natural	111-N04018	11106
5" Length, 40# Natural	111-N05040	11107
8" Length, 40# Natural	111-N08040	11108
11" Length, 50# Natural	111-N11050	11109
14" Length, 50# Natural	111-N14050	11110
18" Length, 120# Natural	111-N18120	11111
24" Length, 175# Natural	111-N24175	11112
36" Length, 175# Natural	111-N36175	11113

DESCRIPTION	PART NUMBER	UPC NUMBER 722170-
4" Length, 18# UV Black	111-B04018	11114
5" Length, 40# UV Black	111-B05040	11115
8" Length, 40# UV Black	111-B08040	11116
11" Length, 50# UV Black	111-B11050	11117
14" Length, 50# UV Black	111-B14050	11118
18" Length, 120# UV Black	111-B18120	11119
24" Length, 175# UV Black	111-B24175	11120
36" Length, 175# UV Black	111-B36175	11121

SCREWDRIVING BITS

400 Hex Allen

Available in 1" or 2" OAL



- Industrial quality
- S-2 Shock Resistant Steel
- HRc 60 Hardness
- Computer Controlled Hardening
- CNC Machine Ground
- 1/4" Shank – SAE standards

1" – Insert Bit

2" – Power Bit

SIZE	SHANK SIZE	PART NUMBER	UPC NUMBER 722170-
1/16" x 1"	1/4"	400.HX.0464	40001
5/64" x 1"	1/4"	400.HX.0564	40002
3/32" x 1"	1/4"	400.HX.0664	40003
7/64" x 1"	1/4"	400.HX.0764	40004
1/8" x 1"	1/4"	400.HX.0864	40005
9/64" x 1"	1/4"	400.HX.0964	40006
5/32" x 1"	1/4"	400.HX.1064	40007
3/16" x 1"	1/4"	400.HX.1264	40008
7/32" x 1"	1/4"	400.HX.1464	40009
1/4" x 1"	1/4"	400.HX.1664	40010
5/16" x 1"	1/4"	400.HX.2064	40011
1/16" x 2"	1/4"	400.HX2.0464	40012
3/32" x 2"	1/4"	400.HX2.0664	40016
7/64" x 2"	1/4"	400.HX2.0764	40019
1/8" x 2"	1/4"	400.HX2.0864	40014
9/64" x 2"	1/4"	400.HX2.0964	40020
5/32" x 2"	1/4"	400.HX2.1064	40018
3/16" x 2"	1/4"	400.HX2.1264	40015
1/4" x 2"	1/4"	400.HX2.1664	40013
5/16" x 2"	1/4"	400.HX2.2064	40017

UNIT PACK: 50

401 Tamper Resistant Hex Allen Inserts

1" OAL



- Industrial quality
- S-2 Shock Resistant Steel
- HRc 60 Hardness
- 1/4" Shank - SAE standards
- Tamper-proof

SIZE	SHANK SIZE	PART NUMBER	UPC NUMBER 722170-
3/32" x 1"	1/4"	401.TR.0664	40104
1/8" x 1"	1/4"	401.TR.0864	40102
9/64" x 1"	1/4"	401.TR.0964	40107
5/32" x 1"	1/4"	401.TR.1064	40105
3/16" x 1"	1/4"	401.TR.1264	40103
7/32" x 1"	1/4"	401.TR.1464	40106
1/4" x 1"	1/4"	401.TR.1664	40101

UNIT PACK: 50

415 Phillips Square



- Industrial Quality
- S-2 Shock Resistant Steel
- HRc 60 Hardness
- 1/4" Shank – SAE standards

1" – Insert Bit

2" – Power Bit

LENGTH	SHANK SIZE	PART NUMBER	UPC NUMBER 722170-
1"	1/4"	415.PSQ2.1	41501
2"	1/4"	415.PSQ2.2	41502

UNIT PACK: 50

SCREWDRIVING BITS

408 ACR

Available in 1" through 6" OAL



- Industrial Quality
- S-2 Shock Resistant Steel
- HRc 60 Hardness
- 1/4" Shank – SAE standards
- ACR "ribs"

ACR stands for Anti-Camout Ribs which are tiny grooves that prevent bits from slipping out.

1" – Insert Bit

2" & Longer – Power Bit

SIZE	SHANK SIZE	PART NUMBER	UPC NUMBER 722170-
#1 x 1"	1/4"	408.ACR1.1	40801
#1 x 2"	1/4"	408.ACR2.1	40802
#1 x 2-3/4"	1/4"	408.ACR3.1	40803
#1 x 3-1/2"	1/4"	408.ACR4.1	40804
#1 x 6"	1/4"	408.ACR6.1	40805
#2 x 1"	1/4"	408.ACR1.2	40806
#2 x 2"	1/4"	408.ACR2.2	40807
#2 x 2-3/4"	1/4"	408.ACR3.2	40808
#2 x 3-1/2"	1/4"	408.ACR4.2	40809
#2 x 6"	1/4"	408.ACR6.2	40810
#2x1" Reduced	1/4"	408.ACR1.2R	40811
#3 x 1"	1/4"	408.ACR1.3	40812
#3 x 2"	1/4"	408.ACR2.3	40813
#3 x 2-3/4"	1/4"	408.ACR3.3	40814
#3 x 3-1/2"	1/4"	408.ACR4.3	40815
#3 x 6"	1/4"	408.ACR6.3	40816

1", 2", Reduced = 50 PER PACK

2-3/4", 3-1/2" = 20 PER PACK

6" = 10 PER PACK

409 Phillips

Available in 1" through 6" OAL



- Industrial Quality
- S-2 Shock Resistant Steel
- HRc 60 Hardness
- 1/4" Shank – SAE standards

1" – Insert Bit

2" & Longer – Power Bit

SIZE	SHANK SIZE	PART NUMBER	UPC NUMBER 722170-
#1x1" Reduced	1/4"	409.PR1.1	40901
#2x1" Reduced	1/4"	409.PR1.2	40902
#3x1" Reduced	1/4"	409.PR1.3	40903
#2x2" Reduced	1/4"	409.PR2.2	40904
#0 x 1"	1/4"	409.PI1.0	40905
#1 x 1"	1/4"	409.PI1.1	40906
#2 x 1"	1/4"	409.PI1.2	40907
#3 x 1"	1/4"	409.PI1.3	40908
#4 x 1"	1/4"	409.PI1.4	40909
#2 Full Hex	1/4"	409.PI1.2H	40919
#0 x 2"	1/4"	409.PB0.2	40910
#1 x 2"	1/4"	409.PB2.1	40911
#1 x 2-3/4"	1/4"	409.PB3.1	40912
#1 x 3-1/2"	1/4"	409.PB4.1	40913
#1 x 6"	1/4"	409.PB6.1	40914
#2 x 2"	1/4"	409.PB2.2	40915
#2 x 2-3/4"	1/4"	409.PB3.2	40916
#2 x 3-1/2"	1/4"	409.PB4.2	40917
#2 x 6"	1/4"	409.PB6.2	40918
#3 x 2"	1/4"	409.PB2.3	40920
#3 x 2-3/4"	1/4"	409.PB3.3	40921
#3 x 3-1/2"	1/4"	409.PB4.3	40922
#3 x 6"	1/4"	409.PB6.3	40923

UNIT PACK: 50

SCREWDRIVING BITS

410 Phillips Impact



1-1/4" OAL

- Industrial Quality
- S-2 Shock Resistant Steel
- HRc 60 Hardness
- 5/16" Shank - SAE standards

SIZE	SHANK SIZE	PART NUMBER	UPC NUMBER 722170-
#1 x 1-1/4"	5/16"	410.PI1.1	41001
#2 x 1-1/4"	5/16"	410.PI1.2	41002
#3 x 1-1/4"	5/16"	410.PI1.3	41003
#4 x 1-1/4"	5/16"	410.PI1.4	41004

UNIT PACK: 50

411 POSIDRIV Inserts



- Industrial Quality
- S-2 Shock Resistant Steel
- HRc 60 Hardness
- 1/4" Shank – SAE standards
- Straight Flanks, Radial Indentations

A set of lines 45 degrees from the center recess allows for a greater amount of torque and control.

SIZE	SHANK SIZE	PART NUMBER	UPC NUMBER 722170-
#1 x 1"	1/4"	411.PZ1.1	41101
#2 x 1"	1/4"	411.PZ1.2	41102
#3 x 1"	1/4"	411.PZ1.3	41103
#1 Reduced x 1-15/16"	1/4"	411.PZ2.1	41104
#2 Reduced x 1-15/16"	1/4"	411.PZ2.2	41105
#3 Reduced x 1-15/16"	1/4"	411.PZ2.3	41106

UNIT PACK: 50

412 Slotted



- Industrial Quality
- S-2 Shock Resistant Steel
- HRc 60 Hardness
- 1/4" & 5/16" Shank – SAE standards

1" – Insert Bit

2" – Power Bit

SIZE	SHANK SIZE	PART NUMBER	UPC NUMBER 722170-
5MM. x 1"	1/4"	412.SL1.5	41201
6MM. x 1"	1/4"	412.SL1.6	41202
7MM. x 1"	1/4"	412.SL1.7	41203
#8 x 1-1/2"	5/16"	412.SL1.8	41204
#10 x 1-1/2"	5/16"	412.SL1.10	41205
5MM. x 2"	1/4"	412.SL2.5	41206
6MM. x 2"	1/4"	412.SL2.6	41207
7MM. x 2"	1/4"	412.SL2.7	41208
8MM. x 2"	1/4"	412.SL2.8	41209

UNIT PACK: 50

413 Spanner



- Industrial Quality
- S-2 Shock Resistant Steel
- HRc 60 Hardness
- 1/4" Shank – SAE standards

SIZE	SHANK SIZE	PART NUMBER	UPC NUMBER 722170-
#4 x 1"	1/4"	413.SP1.4	41301
#6 x 1"	1/4"	413.SP1.6	41302
#8 x 1"	1/4"	413.SP1.8	41303
#10 x 1"	1/4"	413.SP1.10	41304
#12 x 1"	1/4"	413.SP1.12	41305

UNIT PACK: 50

SCREWDRIVING BITS

416 Square



- Industrial Quality
- S-2 Shock Resistant Steel
- HRc 60 Hardness
- 1/4" Shank – SAE standards
- Tapered Socket

Taper makes it easier for the screw to be retained to reduce damage for high torque usage.

1" – Insert Bit

2" & Longer – Power Bit

SIZE	SHANK SIZE	PART NUMBER	UPC NUMBER 722170-
#0 x 1"	1/4"	416.SQ0.1	41601
#1 x 1"	1/4"	416.SQ1.1	41602
#1 x 2"	1/4"	416.SQ2.1	41605
#1 x 2-3/4"	1/4"	416.SQ3.1	41606
#1 x 3-1/2"	1/4"	416.SQ4.1	41607
#1 x 6"	1/4"	416.SQ6.1	41608
#2 x 1"	1/4"	416.SQ1.2	41603
#2 x 2"	1/4"	416.SQ2.2	41609
#2 x 2-3/4"	1/4"	416.SQ3.2	41610
#2 x 3-1/2"	1/4"	416.SQ4.2	41611
#2 x 6"	1/4"	416.SQ6.2	41612
#3 x 1"	1/4"	416.SQ1.3	41604
#3 x 2"	1/4"	416.SQ2.3	41613
#3 x 2-3/4"	1/4"	416.SQ3.3	41614
#3 x 3-1/2"	1/4"	416.SQ4.3	41615
#3 x 6"	1/4"	416.SQ6.3	41616

1", 2" = 50 PER PACK
 2-3/4", 3-1/2" = 20 PER PACK
 6" = 10 PER PACK

418 Impact Resistant Square



- Industrial Quality
- 1/4" Shank – SAE standards
- Extra Hardened Surface

Extra Hardened exterior coating improves the durability of the bit by resisting wear and tear.

LENGTH	SHANK SIZE	PART NUMBER	UPC NUMBER 722170-
#1 x 1"	1/4"	418.ISB.11	41832
#2 x 1"	1/4"	418.ISB.12	41833
#3 x 1"	1/4"	418.ISB.13	41834
#1 x 2"	1/4"	418.IPB.21	41835
#2 x 2"	1/4"	418.IPB.22	41836
#3 x 2"	1/4"	418.IPB.23	41837

UNIT PACK: 50

418 Impact Resistant Phillips



- Industrial Quality
- 1/4" Shank – SAE standards
- Extra Hardened Surface

Extra Hardened exterior coating improves the durability of the bit by resisting wear and tear.

SIZE	SHANK SIZE	PART NUMBER	UPC NUMBER 722170-
#1 x 1"	1/4"	418.IRB.11	41826
#2 x 1"	1/4"	418.IRB.12	41827
#3 x 1"	1/4"	418.IRB.13	41828
#1 x 2"	1/4"	418.IPB.21	41829
#2 x 2"	1/4"	418.IPB.22	41830
#3 x 2"	1/4"	418.IPB.23	41831

UNIT PACK: 50

SCREWDRIVING BITS

417 Star

- Industrial Quality
- S-2 Shock Resistant Steel
- HRC-60 Hardness
- 1/4" & 5/16" Shank – SAE standards

Commonly used in automobiles and computers.

1" – Insert Bit

2", 2-3/4" – Power Bit

3-1/2", 6" – TORX Bit

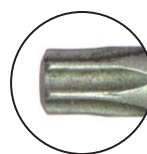

SIZE	SHANK SIZE	PART NUMBER	UPC NUMBER 722170-
T6 x 1"	1/4"	417.ST1.6	41701
T7 x 1"	1/4"	417.ST1.7	41702
T8 x 1"	1/4"	417.ST1.8	41703
T9 x 1"	1/4"	417.ST1.9	41704
T10 x 1"	1/4"	417.ST1.10	41705
T15 x 1"	1/4"	417.ST1.15	41706
T20 x 1"	1/4"	417.ST1.20	41707
T25 x 1"	1/4"	417.ST1.25	41708
T27 x 1"	1/4"	417.ST1.27	41709
T30 x 1"	1/4"	417.ST1.30	41710
T40 x 1"	1/4"	417.ST1.40	41711
T8 x 2"	1/4"	417.PB2.8	41712
T9 x 2"	1/4"	417.PB2.9	41713
T10 x 2"	1/4"	417.PB2.10	41714
T15 x 2"	1/4"	417.PB2.15	41715
T20 x 2"	1/4"	417.PB2.20	41716
T25 x 2"	1/4"	417.PB2.25	41717
T27 x 2"	1/4"	417.PB2.27	41718
T30 x 2"	1/4"	417.PB2.30	41719
T40 x 2"	1/4"	417.PB2.40	41720
T8 x 2-3/4"	1/4"	417.PB3.8	41721
T10 x 2-3/4"	1/4"	417.PB3.10	41722
T15 x 2-3/4"	1/4"	417.PB3.15	41723
T20 x 2-3/4"	1/4"	417.PB3.20	41724

SIZE	SHANK SIZE	PART NUMBER	UPC NUMBER 722170-
T25 x 2-3/4"	1/4"	417.PB3.25	41725
T27 x 2-3/4"	1/4"	417.PB3.27	41726
T30 x 2-3/4"	1/4"	417.PB3.30	41727
T40 x 2-3/4"	1/4"	417.PB3.40	41728
T8 x 3-1/2"	1/4"	417.PB4.8	41729
T10 x 3-1/2"	1/4"	417.PB4.10	41730
T15 x 3-1/2"	1/4"	417.PB4.15	41731
T20 x 3-1/2"	1/4"	417.PB4.20	41732
T25 x 3-1/2"	1/4"	417.PB4.25	41733
T27 x 3-1/2"	1/4"	417.PB4.27	41734
T30 x 3-1/2"	1/4"	417.PB4.30	41735
T40 x 3-1/2"	1/4"	417.PB4.40	41736
T8 x 6"	1/4"	417.PB6.8	41737
T10 x 6"	1/4"	417.PB6.10	41738
T15 x 6"	1/4"	417.PB6.15	41739
T20 x 6"	1/4"	417.PB6.20	41740
T25 x 6"	1/4"	417.PB6.25	41741
T27 x 6"	1/4"	417.PB6.27	41742
T30 x 6"	1/4"	417.PB6.30	41743
T40 x 6"	1/4"	417.PB6.40	41744

1", 2" = 50 PER PACK
 2-3/4", 3-1/2" = 20 PER PACK
 6" = 10 PER PACK

418 Star (5/16" Shank)

SIZE	SHANK SIZE	PART NUMBER	UPC NUMBER 722170-
T30 x 1-1/4"	5/16"	418.5.T30	41801
T40 x 1-1/4"	5/16"	418.5.T40	41802
T45 x 1-1/4"	5/16"	418.5.T45	41803
T50 x 1-1/4"	5/16"	418.5.T50	41804

UNIT PACK: 50

SCREWDRIVING BITS

418 Tamper Resistant Star



- Industrial Quality
- S-2 Shock Resistant Steel
- HRc-60 Hardness
- 1/4" & 5/16" Shank – SAE standards
- Tamper-proof

Commonly used in automobiles and computers.

SIZE	SHANK SIZE	PART NUMBER	UPC NUMBER 722170-
T8 x 1"	1/4"	418.1.TT8	41808
T9 x 1"	1/4"	418.1.TT9	41809
T10 x 1"	1/4"	418.1.TT10	41810
T15 x 1"	1/4"	418.1.TT15	41811
T20 x 1"	1/4"	418.1.TT20	41812
T25 x 1"	1/4"	418.1.TT25	41813
T27 x 1"	1/4"	418.1.TT27	41814
T30 x 1"	1/4"	418.1.TT30	41815
T40 x 1"	1/4"	418.1.TT40	41816
T40	5/16"	418.5.TT40	41805
T45	5/16"	418.5.TT45	41806
T50	5/16"	418.5.TT50	41807
T8 x 2"	1/4"	418.2.TT8	41817
T9 x 2"	1/4"	418.2.TT9	41818
T10 x 2"	1/4"	418.2.TT10	41819
T15 x 2"	1/4"	418.2.TT15	41820
T20 x 2"	1/4"	418.2.TT20	41821
T25 x 2"	1/4"	418.2.TT25	41822
T27 x 2"	1/4"	418.2.TT27	41823
T30 x 2"	1/4"	418.2.TT30	41824
T40 x 2"	1/4"	418.2.TT40	41825

UNIT PACK: 50

414 Dry Wall Driver



- Industrial Quality
- S-2 Shock Resistant Steel, HRc-60 Hardness
- 1/4" Shank – SAE standards
- Pre-Set Depth Stop Collar

Ideal for contractors working with drywall and similar materials such as insulation. Collar prevents the drill from going too deep into the drywall.

SIZE	SHANK SIZE	PART NUMBER	UPC NUMBER 722170-
1"	1/4"	414.DWD.1	41401
2"	1/4"	414.DWD.2	41402

1" = 50 PER PACK
2" = 20 PER PACK

422 Double End

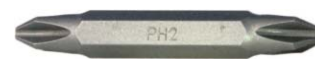

- Industrial Quality
- S-2 Shock Resistant Steel, HRc-60 Hardness
- 1/4" Shank – SAE standards

DES.	SHANK SIZE	PART NUMBER	UPC NUMBER 722170-
#1 Phillips x #2 Phillips	1/4"	422.P1P2	42201
#2 Phillips x #2 Phillips	1/4"	422.P2P2	42202
#2 Phillips x 6MM. Slot	1/4"	422.P2S6	42203
#2 Phillips x 8 MM. Slot	1/4"	422.P2S8	42204
#1 Square x #2 Square	1/4"	422.Q1Q2	42205

UNIT PACK: 50

SCREWDRIVING BITS

419 Magnetic Bit Holder w/C-Ring



- Industrial Quality (Stainless Steel Construction)
- 1/4" Shank – SAE standards
- Magnetic Core

Magnetic Core keeps bits and fasteners in place to improve efficiency and accuracy. Commonly used to make drilling in the home easier.

LENGTH	SHANK SIZE	PART NUMBER	UPC NUMBER 722170-
2"	1/4"	419.BHR.02	41901
3"	1/4"	419.BHR.03	41902
4"	1/4"	419.BHR.04	41903
6"	1/4"	419.BHR.06	41904
8"	1/4"	419.BHR.08	41905
10"	1/4"	419.BHR.10	41906
12"	1/4"	419.BHR.12	41907

UNIT PACK: 10

419 Quick Change Bit Holder



- Industrial Quality
- 1/4" Shank – SAE standards
- Spring Loaded w/ Magnetic Bit Tip Holder

Spring mechanism allows for one-handed loading and unloading in releasing fasteners.

2-3/8", 3" = Push Type

6", 12" = Extenders

LENGTH	SHANK SIZE	PART NUMBER	UPC NUMBER 722170-
2-3/8"	1/4"	419.BHQC.2	41913
3"	1/4"	419.BHQC.3	41914
6"	1/4"	419.HQC.6	41916
12"	1/4"	419.HQC.12	41915

UNIT PACK: 50

419 Magnetic Bit Holder w/Cap O-Ring



- Industrial Quality (Stainless Steel Construction)
- 1/4" Shank – SAE standards
- Magnetic Core

Magnetic Core keeps bits and fasteners in place to improve efficiency and accuracy.

LENGTH	SHANK SIZE	PART NUMBER	UPC NUMBER 722170-
3"	1/4"	419.BHC.03	41910
6"	1/4"	419.BHC.06	41911
8"	1/4"	419.BHC.08	41912
10"	1/4"	419.BHC.10	41908
12"	1/4"	419.BHC.12	41909

UNIT PACK: 10

421 Screw Guide Magnetic Bit Holder



- Industrial Quality
- Stainless Steel Construction
- 1/4" Shank - SAE standards
- Self-Retracting Guide Sleeve w/ Mag. Bit Holder

Sleeve protects fingers and prevents scratches by holding bits in place. Guide eliminates wobbling and slipping. Commonly used in household construction such as building decks, hanging drywall, and etc.

LENGTH	SHANK SIZE	PART NUMBER	UPC NUMBER 722170-
3"	1/4"	421.BHSG-3	42101
4-3/4"	1/4"	421.BHSG-4	42102

UNIT PACK: 10

SCREWDRIVING BITS

402 & 403 Square Hex Shank Extensions

Available in lengths from 1" to 12"

- Industrial Quality (Chrome Vanadium Finish)
- 1/4" & 7/16" Shank – SAE standards
- Ball Pin Lock



Ball pin allows the extension to be inserted into a socket to reduce wobbling. Commonly used in repair and maintenance.

1/4" Square

LENGTH	SHANK SIZE	PART NUMBER	UPC NUMBER 722170-
1"	1/4"	402.EX01.140	40201
2"	1/4"	402.EX02.140	40204
3"	1/4"	402.EX03.140	40205
4"	1/4"	402.EX04.140	40206
5"	1/4"	402.EX05.140	40207
6"	1/4"	402.EX06.140	40208
8"	1/4"	402.EX08.140	40209
10"	1/4"	402.EX10.140	40202
12"	1/4"	402.EX12.140	40203

3" and smaller = 20 PER PACK
4" and larger = 10 PER PACK

1/2" Square

LENGTH	SHANK SIZE	PART NUMBER	UPC NUMBER 722170-
2-1/8"	7/16"	403.EX02.712	40301
3"	7/16"	403.EX03.712	40302
4"	7/16"	403.EX04.712	40303
6"	7/16"	403.EX06.712	40304

2-1/8", 3" = 20 PER PACK
4", 6" = 10 PER PACK

3/8" Square

LENGTH	SHANK SIZE	PART NUMBER	UPC NUMBER 722170-
1-5/8"	1/4"	402.EX01.380	40210
2"	1/4"	402.EX02.380	40211
3"	1/4"	402.EX03.380	40212
4"	1/4"	402.EX04.380	40213
5"	1/4"	402.EX05.380	40214
6"	1/4"	402.EX06.380	40215
8"	1/4"	402.EX08.380	40216
1-3/4"	7/16"	403.EX01.738	40305
2"	7/16"	403.EX02.738	40306
3"	7/16"	403.EX03.738	40307
4"	7/16"	403.EX04.738	40308
6"	7/16"	403.EX06.738	40309

3" and smaller = 20 PER PACK
4" and larger = 10 PER PACK

405 Non-Magnetic Nut Setters

LENGTH	SHANK SIZE	PART NUMBER	UPC NUMBER 722170-
2-9/16"	1/2"	405.NMS3.120	40501
2-9/16"	1/4"	405.NMS3.140	40502
2-9/16"	3/8"	405.NMS3.380	40503
2-9/16"	5/16"	405.NMS3.516	40504
2-9/16"	7/16"	405.NMS3.716	40505

UNIT PACK: 10



1/4" Hex Shank

- Industrial Quality
- Chrome Vanadium Steel
- Recessed Corners

SCREWDRIVING BITS

407 Magnetic Nut Setters



1/4" Hex Shank

- Industrial Quality
- S2 Shock Resistant steel
- Recessed Corners maximize contact with hex head fasteners for a tighter grip
- Magnetic Core

Recessed Corners minimizes shavings. Designed to be used in Impact Drivers and Wrenches.

LENGTH	SHANK SIZE	PART NUMBER	UPC NUMBER 722170-
1-3/4"	1/4"	407.MS1.140	40705
2-9/16"	1/4"	407.MS3.140	40707
4"	1/4"	407.MS4.140	40708
6"	1/4"	407.MS6.140	40709
8"	1/4"	407.MS8.140	40710
1-3/4"	5/16"	407.MS1.516	40716
2-9/16"	5/16"	407.MS3.516	40718
4"	5/16"	407.MS4.516	40719
6"	5/16"	407.MS6.516	40720
8"	5/16"	407.MS8.516	40721
1-3/4"	3/8"	407.MS1.380	40711
2-9/16"	3/8"	407.MS3.380	40712
4"	3/8"	407.MS4.380	40713
6"	3/8"	407.MS6.380	40714
8"	3/8"	407.MS8.380	40715
1-3/4"	7/16"	407.MS1.716	40722
2-9/16"	7/16"	407.MS3.716	40723
4"	7/16"	407.MS4.716	40724
6"	7/16"	407.MS6.716	40725
1-3/4"	1/2"	407.MS1.120	40701
2-9/16"	1/2"	407.MS3.120	40702
4"	1/2"	407.MS4.120	40703
6"	1/2"	407.MS6.120	40704

UNIT PACK: 10

407 Lobular Magnetic Nut Setters



1/4" Hex Shank

- Industrial Quality
- S2 Shock Resistant steel
- Lobular Hex Corners prevents damage to hex fasteners
- Magnetic Core

Lobular design drives the fastener on the sides to reduce wear and tear.

LENGTH	SHANK SIZE	PART NUMBER	UPC NUMBER 722170-
1-3/4"	1/4"	407.LM2.140	40734
2-9/16"	1/4"	407.LM3.140	40731
4"	1/4"	407.LM4.140	40732
6"	1/4"	407.LM6.140	40733
12"	1/4"	407.LM12.140	40730
1-3/4"	5/16"	407.LM2.516	40744
2-9/16"	5/16"	407.LM3.516	40741
4"	5/16"	407.LM4.516	40742
6"	5/16"	407.LM6.516	40743
12"	5/16"	407.LM12.516	40740
1-3/4"	3/8"	407.LM2.380	40739
2-9/16"	3/8"	407.LM3.380	40736
4"	3/8"	407.LM4.380	40737
6"	3/8"	407.LM6.380	40738
12"	3/8"	407.LM12.380	40735
1-3/4"	7/16"	407.LM2.716	40749
2-9/16"	7/16"	407.LM3.716	40746
4"	7/16"	407.LM4.716	40747
6"	7/16"	407.LM6.716	40748
12"	7/16"	407.LM12.716	40745
1-3/4"	1/2"	407.LM2.120	40729
2-9/16"	1/2"	407.LM3.120	40726
4"	1/2"	407.LM4.120	40727
6"	1/2"	407.LM6.120	40728
12"	1/2"	407.LM12.120	40725

UNIT PACK: 10

421 Screw Extractors

- Perfect for removing damaged bolts, screws, or pipe threads while they are stuck in the fastening hole
- Heavy duty, heat-treated carbon steel material for a stronger and longer lasting screw extractor
- SQUARE END Shank
- SPIRAL flutes instantly removes plug and debris while turning



PART#	SIZE	SHANK SIZE	REMOVES SCREW SIZE (IN)	REMOVES PIPE THREAD (IN)	UPC NUMBER 722170-
421-SE002	#2	7/64"	5/32"... 7/32"		42104
421-SE004	#4	1/4"	9/32"... 3/8"	1/8"	42106
421-SE005	#5	19/64"	3/8"... 5/8"	1/4"	42107
421-SE006	#6	7/16"	5/8"... 7/8"	3/8"	42108
421-SE007	#7	9/16"	7/8"... 1-1/8"	1/2"	42109
421-SE008	#8	3/4"	1-1/8"... 1-3/8"	3/4"	42110
421-SE009	#9	1-1/16"	1-3/8"... 2"	1"	42111

815 Stainless Steel Hose Clamps

- Industrial Quality
- Stainless Steel finish

Stainless Steel finish is corrosion resistant for a longer lasting and stronger hose clamp. Perfect for quick, durable, and economical plumbing repair applications. Prevents hoses and pipes of various materials from getting rusty. Worm drive design covers up holes in pipes and hoses to prevent flow leakage.



DES.	MIN. DIA.	MAX. DIA.	PART NUMBER	UPC NUMBER 722170-
#4	7/32"	5/8"	815.0004	81501
#6	3/8"	7/8"	815.0006	81502
#8	7/16"	1"	815.0008	81503
#10	9/16"	1-1/16"	815.0010	81504
#12	1-1/16"	1-1/4"	815.0012	81505
#16	1-3/16"	1-1/2"	815.0016	81506
#20	1-3/16"	1-3/4"	815.0020	81507
#24	1-1/16"	2"	815.0024	81508
#28	1-5/16"	2-1/4"	815.0028	81509
#32	1-9/16"	2-1/2"	815.0032	81510
#36	1-13/16"	2-3/4"	815.0036	81511
#40	2-1/16"	3"	815.0040	81512
#44	2-5/16"	3-1/4"	815.0044	81513
#48	2-9/16"	3-1/2"	815.0048	81514
#52	2-13/16"	3-3/4"	815.0052	81515
#56	3-1/16"	4"	815.0056	81516
#64	3-9/16"	4-1/2"	815.0064	81517
#72	4-1/8"	5"	815.0072	81518
#80	4-5/8"	5-1/2"	815.0080	81519
#88	5-1/8"	6"	815.0088	81520
#96	5-5/8"	6-1/2"	815.0096	81521
#104	6-1/8"	7"	815.0104	81522

UNIT PACK: 10

NEW ITEMS

CROSS REFERENCE CHARTS

Ship Augers Heavy Duty Reference Guide

MAG 357DLX Short Ship Augers / Lenox / Greenlee / Milwaukee / GB

DIA	MAG-BIT HVY. DUTY	OAL	MAG BIT STD. DUTY	OAL	LENOX	OAL	GREENLEE	OAL	MILWAUKEE	OAL	GB	OAL
1/2"	357DLX.0816QC	8"	715-0816	6"	N/A		N/A		N/A		N/A	
9/16"	357DLX.0916QC	8"	715-0916	6"	N/A		N/A		N/A		N/A	
5/8"	357DLX.1016QC	8"	715-1016	6"	31030-07A-1016	7-1/2"	61/62PTS-5/8	7-5/8"	N/A		SA-10S	7-1/2"
11/16"	357DLX.1116QC	8"	715-1116	6"	31031-07A-1116	7-1/2"	61/62PTS-11/16	7-5/8"	48-13-0683	6"	SA-11S	7-1/2"
3/4"	357DLX.1216QC	8"	715-1216	6"	31032-07A-1216	7-1/2"	61/62PTS-3/4	7-5/8"	48-13-0753	6"	SA-12S	7-1/2"
13/16"	357DLX.1316QC	8"	715-1316	6"	31033-07A-1316	7-1/2"	61/62PTS-13/16	7-5/8"	48-13-0813	6"	SA-13S	7-1/2"
7/8"	357DLX.1416QC	8"	715-1416	6"	31034-07A-1416	7-1/2"	61/62PTS-7/8	7-5/8"	48-13-0873	6"	SA-14S	7-1/2"
15/16"	357DLX.1516QC	8"	715-1516	6"	31035-07A-1516	7-1/2"	N/A		48-13-0933	6"	N/A	
1"	357DLX.1616QC	8"	715-1616	6"	31036-07A-1616	7-1/2"	61/62PTS-1	7-5/8"	48-13-1003	6"	SA-16S	7-1/2"
1-1/16"	N/A		N/A		31037-07A-1716	7-1/2"	N/A		48-13-1063	6"	N/A	
1-1/8"	357DLX.1816QC	8"	715-1816	6"	31038-07A-1816	7-1/2"	61/62PTS-1-1/8	7-5/8"	48-13-1123	6"	SA-18S	7-1/2"
1-1/4"	357DLX.2016QC	8"	715-2016	6"	31040-07A-2016	7-1/2"	61/62PTS-1-1/4	7-5/8"	48-13-1253	6"	SA-20S	7-1/2"
1-3/8"	357DLX.2216QC	8"	715-2216	6"	31042-07A-2216	7-1/2"	N/A		48-13-1373	6"	N/A	
1-1/2"	357DLX.2416QC	8"	715-2416	6"	31044-07A-2416	7-1/2"	N/A		48-13-1503	6"	N/A	

MAG 357DLX Short Ship Augers / Bosch / Irwin / Dewalt / Ideal / Klein

continued from table above

DIA	BOSCH	OAL	IRWIN	OAL	DEWALT	OAL	IDEAL	OAL	KLEIN	OAL
1/2"	ASHST08	7-1/2"	42408	7-1/2"	N/A		N/A		N/A	
9/16"	ASHST09	7-1/2"	42409	7-1/2"	N/A		N/A		N/A	
5/8"	ASHST10	7-1/2"	42410	7-1/2"	DW1665	7-1/2"	35-810	7-1/2"	N/A	
11/16"	ASHST11	7-1/2"	42411	7-1/2"	DW1666	7-1/2"	35-811	7-1/2"	53401	6"
3/4"	ASHST12	7-1/2"	42412	7-1/2"	DW1667	7-1/2"	35-812	7-1/2"	53402/53426	6"/ 7-3/4"
13/16"	ASHST13	7-1/2"	42413	7-1/2"	DW1668	7-1/2"	35-813	7-1/2"	53403	6"
7/8"	ASHST14	7-1/2"	42414	7-1/2"	DW1669	7-1/2"	35-814	7-1/2"	53404/53428	6"/ 7-3/4"
15/16"	N/A	7-1/2"	N/A	7-1/2"	DW1670	7-1/2"	N/A		53405	6"
1"	ASHST16	7-1/2"	42416	7-1/2"	DW1671	7-1/2"	35-815	7-1/2"	53406/53429	6"/ 7-3/4"
1-1/16"	N/A	7-1/2"	N/A	7-1/2"	DW1672	7-1/2"	N/A		53407	6"
1-1/8"	ASHST18	7-1/2"	42418	7-1/2"	DW1673	7-1/2"	35-816	7-1/2"	53408/53430	6"/ 7-3/4"
1-1/4"	ASHST20	7-1/2"	42420	7-1/2"	DW1674	7-1/2"	35-817	7-1/2"	53409/53431	6"/ 7-3/4"
1-3/8"	ASHST22	7-1/2"	42422	7-1/2"	DW1675	7-1/2"	N/A		53410	6"
1-1/2"	ASHST24	7-1/2"	42424	7-1/2"	DW1676	7-1/2"	N/A		53411	6"

Ship Augers Heavy Duty Reference Guide

MAG 303DLX Long Ship Augers / Lenox / Greenlee / Milwaukee / GB

DIA	MAG-BIT HVY. DUTY	OAL	MAG BIT STD. DUTY	OAL	LENOX	OAL	GREENLEE	OAL	MILWAUKEE	OAL	GB	OAL
3/8"	303DLX.0616QC	18"	735-0616	17"	N/A		N/A		N/A		N/A	
7/16"	303DLX.0716QC	18"	735-0716	17"	N/A		N/A		N/A		N/A	
1/2"	303DLX.0816QC	18"	735-0816	17"	N/A		66PT-1/2	18"	N/A		SA-08	17"
9/16"	303DLX.0916QC	18"	735-0916	17"	31009-008-0916	18"	N/A		48-13-5560	18"	N/A	
5/8"	303DLX.1016QC	18"	735-1016	17"	31010-008-1016	18"	66PT-5/8	18"	48-13-5620	18"	SA-10	17"
11/16"	303DLX.1116QC	18"	735-1116	17"	31011-008-1116	18"	66PT-11/16	18"	48-13-5680	18"	SA-11	17"
3/4"	303DLX.1216QC	18"	735-1216	17"	31012-008-1216	18"	66PT-3/4	18"	48-13-5750	18"	SA-12	17"
13/16"	303DLX.1316QC	18"	735-1316	17"	31013-008-1316	18"	66PT-1316	18"	48-13-5810	18"	SA-13	17"
7/8"	303DLX.1416QC	18"	735-1416	17"	31014-008-1416	18"	66PT-7/8	18"	48-13-5870	18"	SA-14	17"
15/16"	303DLX.1516QC	18"	735-1516	17"	31015-008-1516	18"	66PT-15/16	18"	48-13-5930	18"	SA-15	17"
1"	303DLX.1616QC	18"	735-1616	17"	31016-008-1616	18"	66PT-1	18"	48-13-6000	18"	SA-16	17"
1-1/16"	N/A		735-1716	17"	31017-008-1716	18"	N/A		48-13-6010	18"	N/A	
1-1/8"	303DLX.1816QC	18"	735-1816	17"	31018-008-1816	18"	66PT-1-1/8	18"	48-13-6120	18"	SA-18	17"
1-1/4"	303DLX.2016QC	18"	735-2016	17"	31020-008-2016	18"	66PT-1-1/4	18"	48-13-6250	18"	SA-20	17"
1-3/8"	303DLX.2216QC	18"	735-2216	17"	31022-008-2216	18"	N/A		48-13-6370	18"	N/A	
1-1/2"	303DLX.2416QC	18"	735-2416	17"	31024-008-2416	18"	N/A		48-13-6500	18"	N/A	

CROSS REFERENCE CHARTS

Ship Augers Heavy Duty Reference Guide

MAG 303DLX Long Ship Augers / Bosch / Irwin / Dewalt / Ideal / Klein

DIA	BOSCH	OAL	IRWIN	OAL	DEWALT	OAL	IDEAL	OAL	KLEIN	OAL
3/8"	ASHLT06	17"	47406	17"	N/A		N/A		N/A	
7/16"	ASHLT07	17"	47407	17"	N/A		N/A		N/A	
1/2"	ASHLT08	17"	47408	17"	N/A		35-820	17"	N/A	
9/16"	ASHLT09	17"	47409	17"	DW1680	17"	N/A		53434	18"
5/8"	ASHLT10	17"	47410	17"	DW1681	17"	35-821	17"	53435	18"
11/16"	ASHLT11	17"	47411	17"	DW1682	17"	35-822	17"	53436	18"
3/4"	ASHLT12	17"	47412	17"	DW1683	17"	35-823	17"	53437	18"
13/16"	ASHLT13	17"	47413	17"	DW1684	17"	35-824	17"	53438	18"
7/8"	ASHLT14	17"	47414	17"	DW1685	17"	35-825	17"	53439	18"
15/16"	ASHLT15	17"	47415	17"	DW1686	17"	35-826	17"	53440	18"
1"	ASHLT16	17"	47416	17"	DW1687	17"	35-827	17"	53441	18"
1-1/16"	ASHLT17	17"	47417	17"	DW1688	17"	N/A		53442	18"
1-1/8"	ASHLT18	17"	47418	17"	DW1689	17"	35-828	17"	53443	18"
1-3/16"	N/A		N/A		N/A		N/A			
1-1/4"	ASHLT20	17"	47420	17"	DW1690	17"	35-829	17"	53444	18"
1-5/16"	N/A		N/A		N/A		N/A			
1-3/8"	ASHLT22	17"	47422	17"	DW1691	17"	N/A		53445	18"
1-1/2"	ASHLT24	17"	47424	17"	DW1692	17"	N/A		53446	18"

Step Drill Cross Reference Guide

MAG-BIT		IRWIN				M.K.			CULLY	
LENOX	UNIBIT	MILWAUKEE	BOSCH	GREENLEE	KLEIN	IDEAL	MORSE	DOTTIE	MINERELLAC	
851.050A	VB1	1	48-89-9100	SDH1	34401	59001	35-511	ESD01	DSB13	86708
851.0750	VB3	3	48-89-9105	SDH6	N/A	59003	35-512	ESD04	DSB9	N/A
851.1125	N/A	N/A	N/A	SDH4	N/A	N/A	N/A	N/A	DSB12L	86712
851.1375	N/A	N/A	N/A	N/A	N/A	59004	N/A	N/A	DSB11	86722
851.0875	N/A	4	48-89-9130	SDH2	34403	59014	N/A	ESD03	DSB12S	86714
851.0500B	VB4	2	N/A	N/A	36402	59005	35-516	ESD02	DSB6	N/A
851.1125B	VB11	N/A	48-89-9135	SDH11	36413	59011	N/A	ESD05	N/A	86718
851.1375B	VB12	N/A	N/A	SDH5	36414	N/A	N/A	N/A	N/A	N/A
851.0750B	N/A	N/A	N/A	SDH12	N/A	N/A	N/A	N/A	N/A	N/A
851.1000	VB2	20	48-89-9110	SDH7	N/A	59002	N/A	ESD08	N/A	N/A
851.1375R*	N/A	21	N/A	SDH9	N/A	N/A	N/A	ESD09	N/A	N/A
851.1500	N/A	N/A	N/A	N/A	N/A	N/A	N/A	N/A	N/A	86724
850.0500	VB6	10	48-90-9125	N/A	34410	59007	N/A	ESD07	N/A	N/A
850.0875	VB7	11	48-89-9115	N/A	34411	59008	35-517	ESD10	N/A	86814

*For enlarging holes, requires pilot hole

Self Feed Cross Reference Guide

DIA	MAG-BIT	OAL	LENOX	OAL	MILWAUKEE	OAL	BOSCH	OAL	IRWIN	OAL	DEWALT	OAL	MAKITA	OAL
	7/16" HEXQ/C		1/2" SHANK		7/16" HEXQ/C		1/2" SHANK		7/16" HEXQ/C		7/16" SHANK		1/2" SHANK	
1"	785.1616QC	6"	33100-LL100	6"	48-25-1001	4-5/8"	SF1001	4-5/8"	43016	4-5/8"	DW1630	4-5/8"	714101-A	4-5/8"
1-1/8"	785.1816QC	6"	33112-LL112	6"	48-25-1121	4-5/8"	SF1121	4-5/8"	43018	4-5/8"	DW1631	4-5/8"	714102-A	4-5/8"
1-1/4"	785.2016QC	6"	33125-LL125	6"	48-25-1251	4-5/8"	SF1251	4-5/8"	43020	4-5/8"	DW1632	4-5/8"	714103-A	4-5/8"
1-3/8"	785.2216QC	6"	33137-LL137	6"	48-25-1371	4-5/8"	SF1371	4-5/8"	43022	4-5/8"	DW1633	4-5/8"	714104-A	4-5/8"
1-1/2"	785.2416QC	6"	33150-LL150	6"	48-25-1501	4-5/8"	SF1501	4-5/8"	43024	4-5/8"	DW1634	4-5/8"	714105-A	4-5/8"
1-3/4"	785.2816QC	6"	33175-LL175	6"	48-25-1751	4-5/8"	SF1751	4-5/8"	43028	4-5/8"	DW1635	4-5/8"	714106-A	4-5/8"
2"	785.3216QC	6"	33200-LL200	6"	48-25-2001	4-5/8"	SF2001	4-5/8"	43032	4-5/8"	DW1636	4-5/8"	714107-A	4-5/8"
2-1/8"	785.3416QC	6"	33212-LL212	6"	48-25-2121	4-5/8"	SF2121	4-5/8"	43034	4-5/8"	DW1637	4-5/8"	714108-A	4-5/8"
2-1/4"	785.3616QC	6"	33225-LL225	6"	48-25-2251	4-5/8"	SF2251	4-5/8"	43036	4-5/8"	DW1638	4-5/8"	714109-A	4-5/8"
2-9/16"	785.4116QC	6"	33256-LL256	6"	48-25-2561	4-5/8"	SF2561	4-5/8"	43041	4-5/8"	DW1639	4-5/8"	714110-A	4-5/8"
3"	785.4816QC	6"	33300-LL300	6"	48-25-3001	4-5/8"	SF3001	4-5/8"	N/A		DW1640	4-5/8"	714111-A	4-5/8"
3-5/8"	785.5816	6"	33362-LL362	6"	48-25-3621	4-5/8"	SF3621	4-5/8"	N/A		DW1641	4-5/8"	714112-A	4-5/8"
4-1/8"	N/A		N/A		48-25-4125	4-5/8"	N/A		N/A		N/A		N/A	
4-5/8"	785.7416	6"	33462-LL462	6"	48-25-4621	4-5/8"	SF4621	4-5/8"	N/A		DW1642	4-5/8"	714113-A	4-5/8"

CROSS REFERENCE CHARTS

Bi-Metal Hole Saw Cross Reference Chart

SIZE	MAG-BIT	MORSE	AMERICAN SAW (LENOX)	BLACK & DECKER	DEWALT	MAKITA	GREENLEE	MILWAUKEE (4/6)	STARRETT
9/16"	624.0916	AV09	30009-9L	21820	DW1820	7140 01-A	19131	49-56-0006	H0096
5/8"	624.1016	AV10	30010-10L	21821	DW1821	7140 02-A	19132	49-56-0011	H0058
11/16"	624.1116	AV11	30011-11L	21822	DW1822	7140 03-A	19133	49-56-0016	H1016
3/4"	624.1216	AV12	30012-12L	21823	DW1823	7140 04-A	19134	49-56-0021	H0034
13/16"	624.1316	AV13	30013-13L	21824	DW1824	7140 05-A	19135	49-56-0026	H1036
7/8"	624.1416	AV14	30014-14L	21825	DW1825	7140 06-A	19136	49-56-0031	H0078
15/16"	624.1516	AV15	30015-15L	21826	DW1826	7140 07-A	19137	49-56-0036	H1056
1"	624.1616	AV16	30016-16L	21827	DW1827	7140 08-A	19138	49-56-0041	H0100
1-1/16"	624.1716	AV17	30017-17L	21828	DW1828	7140 09-A	19139	49-56-0046	H0116
1-1/8"	624.1816	AV18	30018-18L	21829	DW1829	7140 10-A	19140	49-56-0051	H0118
1-13/16"	624.1916	AV19	30019-19L	21830	DW1830	7140 11-A	19141	49-56-0056	H0136
1-1/4"	624.2016	AV20	30020-20L	21831	DW1831	7140 12-A	19142	49-56-0061	H0114
1-5/16"	624.2116	AV21	30021-21L	21832	DW1832	7140 13-A	19143	49-56-0066	H0156
1-3/8"	624.2216	AV22	30022-22L	21833	DW1833	7140 14-A	19144	49-56-0071	H0138
1-7/16"	624.2316	AV23	30023-23L	21834	DW1834	7140 15-A	19145	49-56-0076	H0176
1-1/2"	624.2416	AV24	30024-24L	21835	DW1835	7140 16-A	19146	49-56-0081	H0112
1-9/16"	624.2516	AV25	30025-25L	21836	DW1836	7140 17-A	19147	49-56-0086	H0196
1-5/8"	624.2616	AV26	30026-26L	21837	DW1837	7140 18-A	19148	49-56-0091	H0158
1-11/16"	624.2716	AV27	30027-27L	21838	DW1838	7140 19-A	19149	49-56-0096	H1116
1-3/4"	624.2816	AV28	30028-28L	21839	DW1839	7140 20-A	19150	49-56-0101	H0134
1-13/16"	624.2916	AV29	30029-29L	21840	DW1840	7140 21-A	19151	49-56-0106	H1136
1-7/8"	624.3016	AV30	30030-30L	21841	DW1841	7140 22-A	19152	49-56-0111	H0178
2"	624.3216	AV32	30032-32L	21842	DW1842	7140 23-A	19153	49-56-0116	H0200
2-1/16"	624.3316	AV33	30033-33L	21843	DW1843	7140 24-A	19154	49-56-0121	H0216
2-1/8"	624.3416	AV34	30034-34L	21844	DW1844	7140 25-A	19155	49-56-0126	H0218
2-1/4"	624.3616	AV36	30036-36L	21845	DW1845	7140 26-A	19156	49-56-0131	H0214
2-5/16"	624.3716	AV37	30037-37L	21846	DW1846	7140 27-A	19157	49-56-0136	H0256
2-3/8"	624.3816	AV38	30038-38L	21847	DW1847	7140 28-A	19158	49-56-0141	H0238
2-1/2"	624.4016	AV40	30040-40L	21848	DW1848	7140 29-A	19159	49-56-0146	H0212
2-9/16"	624.4116	AV41	30041-41L	21849	DW1849	7140 30-A	19160	49-56-0150	H0296
2-5/8"	624.4216	AV42	30042-42L	21850	DW1850	7140 31-A	19161	49-56-0155	H0258
2-3/4"	624.4416	AV44	30044-44L	21851	DW1851	7140 32-A	19162	49-56-0160	H0234
2-7/8"	624.4616	AV46	30046-46L	21852	DW1852	7140 33-A	19163	49-56-0165	H0278
3"	624.4816	AV48	30048-48L	21853	DW1853	7140 34-A	19164	49-56-0170	H0300
3-1/8"	624.5016	AV50	30050-50L	21854	DW1854	7140 35-A	19165	49-56-0175	H0318
3-1/4"	624.5216	AV52	30052-52L	21855	DW1855	7140 36-A	19166	49-56-0180	H0314
3-3/8"	624.5416	AV54	30054-54L	21856	DW1856	7140 37-A	19167	49-56-0185	H0338
3-1/2"	624.5616	AV56	30056-56L	21857	DW1857	7140 38-A	19168	49-56-0190	H0312
3-5/8"	624.5816	AV58	30058-58L	21858	DW1858	7140 39-A	19169	49-56-0195	H0358
3-3/4"	624.6016	AV60	30060-60L	21859	DW1859	7140 40-A	19170	49-56-0200	H0334
3-7/8"	624.6216	AV62	30062-62L	21860	DW1860	7140 41-A	19171	49-56-0205	H0378
4"	624.6416	AV64	30064-64L	21861	DW1861	7140 42-A	19172	49-56-0210	H0400
4-1/8"	624.6616	AV66	30066-66L	21862	DW1862	7140 43-A	19173	49-56-0215	H0418
4-1/4"	624.6816	AV68	30068-68L	21863	DW1863	7140 44-A	19174	49-56-0220	H0414
4-3/8"	624.7016	AV70	30070-70L	21864	DW1864	7140 45-A	19175	49-56-0225	H0438
4-1/2"	624.7216	AV72	30070-72L	21865	DW1865	7140 46-A	19176	49-56-0230	H0412
4-3/4"	624.7616	AV76	30078-78L	21866	DW1866	7140 47-A	19177	49-56-0235	H0434
5"	624.8016	AV80	30080-80L	21867	DW1867	7140 48-A	19178	49-56-0240	H0500
5-1/4"	624.8416	N/A	N/A	N/A	N/A	N/A	19179	N/A	N/A
5-1/2"	624.8816	AV88	30088-88L	21869	DW1868	7140 49-A	19180	49-56-0245	H0512
5-3/4"	624.9216	AV92	N/A	N/A	N/A	N/A	19181	N/A	N/A
6"	624.9616	AV96	30096-96L	21871	DW1871	7140 50-A	19182	49-56-0250	H0600

CROSS REFERENCE CHARTS

MAG-BIT	LENOX	MILWAUKEE	GREENLEE	MK MORSE
624.9002	2L	49-56-7055	37156	M45P
624.9004	6L	49-56-7150	37154	M35PS
624.9005	4L	49-56-6960	38522	M24K
624.9007	1L	49-56-7010	37157	M34
624.9009	5L	49-56-7000	37155	M45P
624.9014B	4321	49-56-8000	37623	MPD401
624.9015B	56PD	49-56-8003	38526	MPDN01
624.9080AD	N/A	N/A	N/A	M44N01
625.9002	N/A	N/A	N/A	N/A
625.9005	N/A	N/A	N/A	N/A
625.9014B	123CT	49-56-8005	N/A	MPD4CT01

Arbors



624.9002



624.9004



624.9009



624.9007



624.9005



625.9002



625.9005

Pilot Bits



624.9014B



624.9015B



624.9080AD



625.9015B



624.9010

Pilot bits sold in packages of 2, 15, & 35 ea.



Springs sold in packages of 5



When drilling metals, use a cutting compound such as MAG-LUBE concentrated cutting fluid.

GENERAL INFORMATION

Auger Bits

**MAG303DLX & MAG357DLX
NAILBOMBER® BITS:**

MAG303DLX overall length 18", diameters from 3/8" to 1-1/2".
MAG357DLX overall length 8", diameters from 1/2" to 1-1/2".

Heavy duty Ship Head auger bits. Molybdenum coated. Molybdenum is a dry lubricant that allows even the greenest chips to pass more easily along the flute. The coating prolongs the life of the bit by dispersing excess heat from the tip and cutting lips during the cutting process. This prevents the loss of hardness developed during heat treatment.

They are induction heat treated and have been designed to cut through any nail they encounter.

- Solid Center makes the bit stronger
- Machined on a true center for straight fast holes

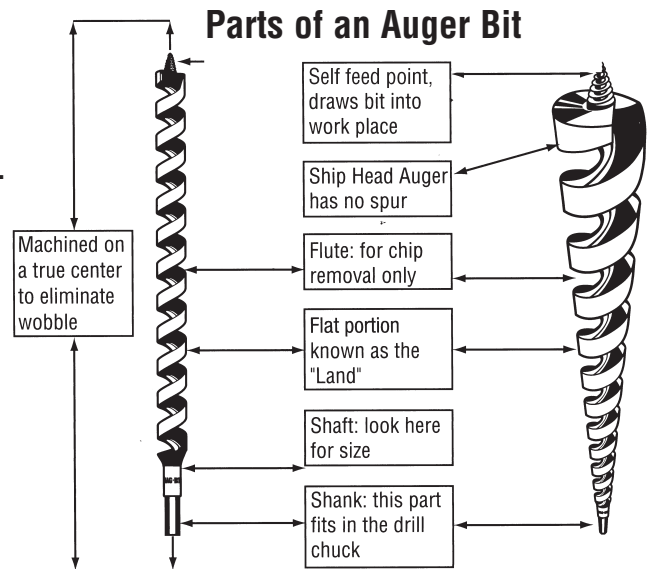
**MAG735 & MAG715:**

MAG735 overall length 17", diameters from 1/4" through 1-1/2".
MAG715 overall length 6", diameters from 1/2" through 1-1/2".

Standard Duty Ship Head Auger Bits: These bits have the same style head (two cutting surfaces) and self feed screw point as the MAG303 and MAG357. They are shorter overall and also have shorter flutes. This makes them less expensive.

These bits are not designed to cut through metal objects they might encounter. For sale when price is more important than quality.

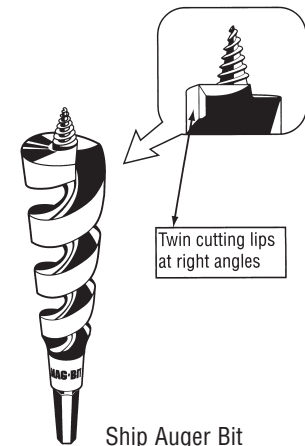
**MAG701, MAG704 & MAG710:**

MAG701 overall length 7-7/8", diameters from 1/4" through 1-1/2".
MAG704 overall length 13", diameters from 5/16" through 1-1/2".
MAG710 overall length 18", diameters from 3/8" through 1-1/2".

Single Spur Auger Bits: The heads of these bits are very different from Ship Head Auger Bits. As the name implies, they have a spur that protrudes from the outer diameter of the head. This is designed to scribe the outer edge of the hole as it is being cut, reducing splinters and blow outs. For best results the bit should not be forced into the work piece.

Only One Cutter: the spur is placed opposite the cutter to allow it to engage the work piece before the cutter, ensuring a clean entrance hole. Many of our competitors do not place the spur in this optimum position. If the spur follows the cutter it is of no value. These bits are manufactured with a solid center for greater strength.

Only MAG-BIT offers the 13" overall length MAG704, useful when a 6" bit is too short for the depth of hole needed, and an 18" bit will not fit into the work piece. Generally these bits are preferred by contractors.

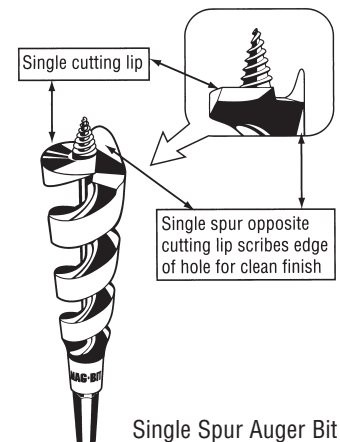

GENERAL INFORMATION

How to Measure a Ship Head Auger Bit

1) Definition: We define "Ship Head" auger bits as wood boring auger bits with *protruded* cutting lips. These bits are generally furnished in hollow center, one flute construction without any outlining spurs.

2) How it works: These bits are designed to drill holes in wood and similar materials rapidly and efficiently, requiring the least effort. The actual drilling is done by the protruded cutting lips. The fluted (grooved) portion of the bits is designed solely for the purpose of evacuating the wood chips towards the rear of the bits. The drill body is smaller than the holes produced by the bits, causing the least amount of friction between the wood and the tool.

3) How to measure the bit size: Attempts are often made to measure the size of the body portion (flute portion) of the bits – a mistaken notion that the thickness of the body portion determines the hole sizes. However, it is very difficult, if not impossible, to take the above measurements because of the odd shapes of the bits (ILL. A). It should also be noted that a measurement obtained in this way does not have any bearing on the actual hole size drilled.

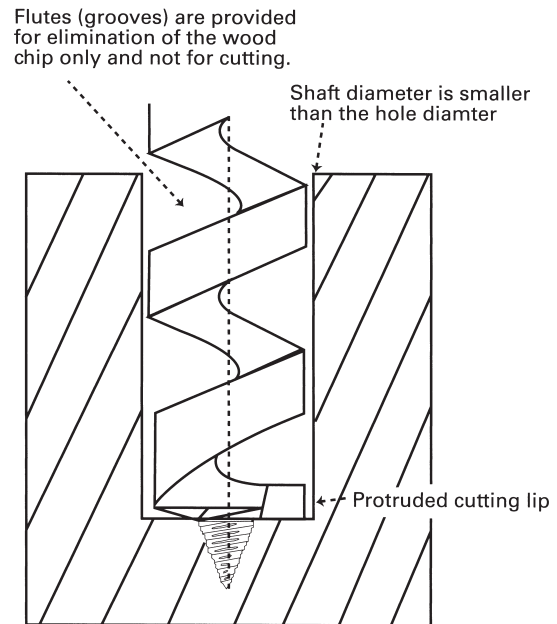

ILL. A

The measurement which determines the hole size is *the distance between the center of the screw point and the outer edge of the protruded cutting lips*. However, it is also difficult to take this measurement because of the odd shaped parts involved.

This method utilized at our factory to take this measurement for production is as follows (ILL. B):

- A)** Measure the distance between the opposite side of the screw point at its base and the outer edge of cutting lips (D1).
- B)** Measure the thickness of the screw point at the base (D2)
- C)** Subtract 1/2 of the (D2) measurement from (D1) to obtain radius (D) of the bit.
- D)** Multiply the above figure (radius) by the factor of 2 to obtain the diameter of the nominal bit size.

4) Nominal bit size and the actual hole size: It is often assumed that auger bits should produce holes equal to the nominal bit size. However, in actuality, the holes produced by this type of bit vary considerably depending upon various factors such as type of wood, dryness of the material etc., etc. Generally, the softer the materials, the smaller the size of the holes produced. Why? The screw point often moves around, especially in softer wood, during the drilling process and the holes produced often come out smaller.

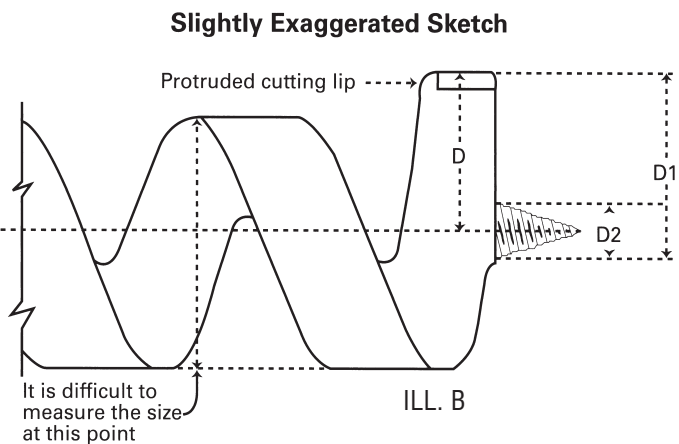

ILL. B

Therefore, in all likelihood, the holes produced by "Ship head auger bits" come out smaller than the normal bit sizes. Since work piece materials cannot be predicted, nominal bit sizes are selected by the theoretical hole size by most manufacturers of auger bits. When the hole size is critical, it is recommended that the users select bits slightly larger in nominal size. For example, for use with 1" bolts or dowels, 1-1/16" or 1-1/8" nominal size bits should be used. For any questions, please call Magnus Industries Inc. at 1-888-624-2487.

GENERAL INFORMATION

MAG785 Saw Tooth/Self Feed Bits: MAG785 overall length 6" and diameters from 1" through 4-5/8".

Drills holes for popular pipe, conduit, tubing and all other large diameter holes in wood. Molybdenum coated for smooth cut and longer life. The quick change hex shank is versatile. It can be used in three jaw chucks, quick change chucks (except 3-5/8" & 4-5/8") and extensions.

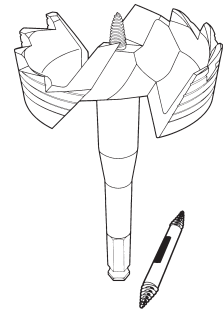

MAG 785
Self-Feed
Saw Tooth Bit

Long Boy Drills: MAG911 overall length 12", diameters from 7/16" through 1-1/4".

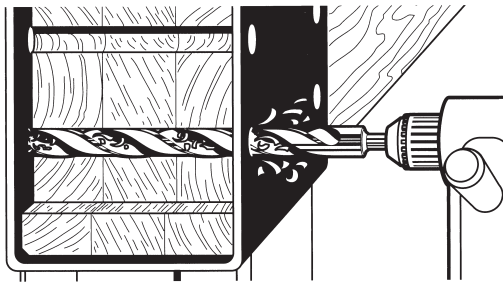

Used to drill holes in beams after the beam has been placed in a metal hanger (think Simpson Strong Tie). These specialty hangers have pre drilled holes, but trying to hit the exit hole when using an auger bit, and missing, causes a lot of broken bits.

The Long Boy Drill is made of High Speed Steel (HSS) and is capable of drilling through metal. These bits are 12" long overall and have a 9" flute. The flute is relieved all along its length to reduce heat and friction build-up. These bits have a 1/2" shank with three flats to help hold the bit in place in the chuck and 118° split point for easy starting.

MAG782 Extensions: MAG782 overall lengths 9-1/2", 12", 18" & 24". Fits bits with 1/4", 5/16" or 7/16" shanks.

Suitable for use with all MAG-BIT wood boring bits including Spade Bits and Saw Tooth/ Self Feed Bits. Supplied with a hex head wrench for tightening set screws. Available in 9.5", 12", 18" and 24" lengths.

1/4" extension should follow bits with a diameter of 1/2" or larger. 5/16" extension should follow bits with a diameter of 5/8" or larger. 7/16" extension should follow bits with a diameter of 7/8" or larger.



MAG 782
Extension

Safety Instructions

- Safety in the use of power tools and their accessories is very important.
- Always use tools in compliance with the tool manufacturers' instructions.
- Always wear adequate eye protection. 
- Be careful to keep long hair and loose clothing away from turning tools and equipment.
- Do not alter power tools or accessories in any way. This may cause hidden defects that can cause the tool or accessory to fail and will void the warranty.
- When drilling through any material do not allow the drill bit to protrude beyond the far side of the hole by more than three times it's diameter. Further protrusion can cause whipping action which will cause the bit to fail, resulting in possible injury to the operator and anyone close by.
- Always use a sharp drill bit.
- Do not exceed 1300 rpm.
- Failure to heed all warnings can result in serious bodily injury.

GENERAL INFORMATION

WIRE GAUGE DECIMAL TABLE

# SIZE	DECIMAL (INCHES)	OAL	FLUTE LENGTH
#1	0.228	3-7/8"	2-5/8"
#2	0.221	3-7/8"	2-5/8"
#3	0.213	3-3/4"	2-1/2"
#4	0.209	3-3/4"	2-1/2"
#5	0.2055	3-3/4"	2-1/2"
#6	0.204	3-3/4"	2-1/2"
#7	0.201	3-5/8"	2-7/16"
#8	0.199	3-5/8"	2-7/16"
#9	0.196	3-5/8"	2-7/16"
#10	0.1935	3-5/8"	2-7/16"
#11	0.191	3-1/2"	2-5/16"
#12	0.189	3-1/2"	2-5/16"
#13	0.185	3-1/2"	2-5/16"
#14	0.182	3-3/8"	2-3/16"
#15	0.18	3-3/8"	2-3/16"
#16	0.177	3-3/8"	2-3/16"
#17	0.173	3-3/8"	2-3/16"
#18	0.1695	3-1/4"	2-1/8"
#19	0.166	3-1/4"	2-1/8"
#20	0.161	3-1/4"	2-1/8"
#21	0.159	3-1/4"	2-1/8"
#22	0.157	3-1/8"	2"
#23	0.154	3-1/8"	2"
#24	0.152	3-1/8"	2"
#25	0.1495	3"	1-7/8"
#26	0.147	3"	1-7/8"
#27	0.144	3"	1-7/8"
#28	0.1405	2-7/8"	1-3/4"
#29	0.136	2-7/8"	1-3/4"
#30	0.1285	2-3/4"	1-5/8"

# SIZE	DECIMAL (INCHES)	OAL	FLUTE LENGTH
#31	0.12	2-3/4"	1-5/8"
#32	0.116	2-3/4"	1-5/8"
#33	0.113	2-5/8"	1-1/2"
#34	0.111	2-5/8"	1-1/2"
#35	0.11	2-5/8"	1-1/2"
#36	0.1065	2-1/2"	1-7/16"
#37	0.104	2-1/2"	1-7/16"
#38	0.1015	2-1/2"	1-7/16"
#39	0.0995	2-3/8"	1-3/8"
#40	0.098	2-3/8"	1-3/8"
#41	0.096	2-3/8"	1-3/8"
#42	0.0935	2-1/4"	1-1/4"
#43	0.089	2-1/4"	1-1/4"
#44	0.086	2-1/8"	1-1/8"
#45	0.082	2-1/8"	1-1/8"
#46	0.081	2-1/8"	1-1/8"
#47	0.0785	2"	1"
#48	0.076	2"	1"
#49	0.073	2"	1"
#50	0.07	2"	1"
#51	0.067	2"	1"
#52	0.0635	1-7/8"	7/8"
#53	0.0595	1-7/8"	7/8"
#54	0.055	1-7/8"	7/8"
#55	0.052	1-7/8"	7/8"
#56	0.0465	1-3/4"	3/4"
#57	0.043	1-3/4"	3/4"
#58	0.042	1-5/8"	11/16"
#59	0.041	1-5/8"	11/16"
#60	0.04	1-5/8"	11/16"

JOBBER FLUTE LENGTH

SIZE	FLUTE LENGTH (INCHES)	SIZE	FLUTE LENGTH (INCHES)
1/16"	7/8"	19/64"	3-1/16"
5/64"	1"	5/16"	3-3/16"
3/32"	1-1/4"	21/64"	3-5/16"
7/64"	1-1/2"	11/32"	3-7/16"
1/8"	1-5/8"	23/64"	3-1/2"
9/64"	1-3/4"	3/8"	3-5/8"
5/32"	2"	25/64"	3-3/4"
11/64"	2-1/8"	13/32"	3-7/8"
3/16"	2-5/16"	27/64"	3-15/16"
13/64"	2-7/16"	7/16"	4-1/16"
7/32"	2-1/2"	29/64"	4-3/16"
15/64"	2-5/8"	15/32"	4-5/16"
1/4"	2-3/4"	31/64"	4-3/8"
17/64"	2-7/8"	1/2"	4-1/2"
9/32"	2-15/16"		

AIRCRAFT FLUTE LENGTH

PART NO.	FLUTE LENGTH (INCHES)
106.06.0432	1-5/8"
106.06.0532	2"
106.06.0632	2-5/16"
106.06.0732	2-1/2"
106.06.0832	2-3/4"
106.06.0932	2-15/16"
106.06.1032	3-3/16"
106.06.1232	3-5/8"
106.06.1432	4-1/16"
106.06.1632	4-1/2"
106.12.0432	1-5/8"
106.12.0532	2"
106.12.0632	2-5/16"
106.12.0732	2-1/2"
106.12.0832	2-3/4"
106.12.0932	2-15/16"
106.12.1032	3-3/16"
106.12.1232	3-5/8"
106.12.1632	4-1/2"

Mag-Bit Warranty

Magnus Industries (MAG-BIT) warrants all products sold by the company against defects in material and workmanship for the life of the product. This warranty does not apply to damage caused by abuse, misuse or alteration. Return defective products to place of purchase for exchange or credit.



When drilling or cutting metals, a cutting compound such as MAG-LUBE *concentrated cutting fluid* should be used or the warranty will be void.

www.magbit.com

- Look at all our great new products.
- Find cross reference charts.
- Download line art.
- Download our complete catalogue.
- Find technical information on our bits & blades.
- RPM Charts.
- Learn how to measure an auger bit.
- Find lots of applications for our step drills.
- Find links to lots of organizations.
- Get a free link to your website.

**Customer Service and Orders:
13095 Park Street
Santa Fe Springs, CA 90670**

Distributed By:



888-MAGBITS
(888-624-2487)

FAX: 866-BIT-GUYS
(866-248-4897)

A series of 25 horizontal dotted lines for writing.





MAG-BIT®



13095 Park Street • Santa Fe Springs, CA 90670 • Tel: 888-MAGBITS (624-2487) • Fax: 866-BITGUYS (248-4897)

orderdesk@magbit.com • www.magbit.com

